

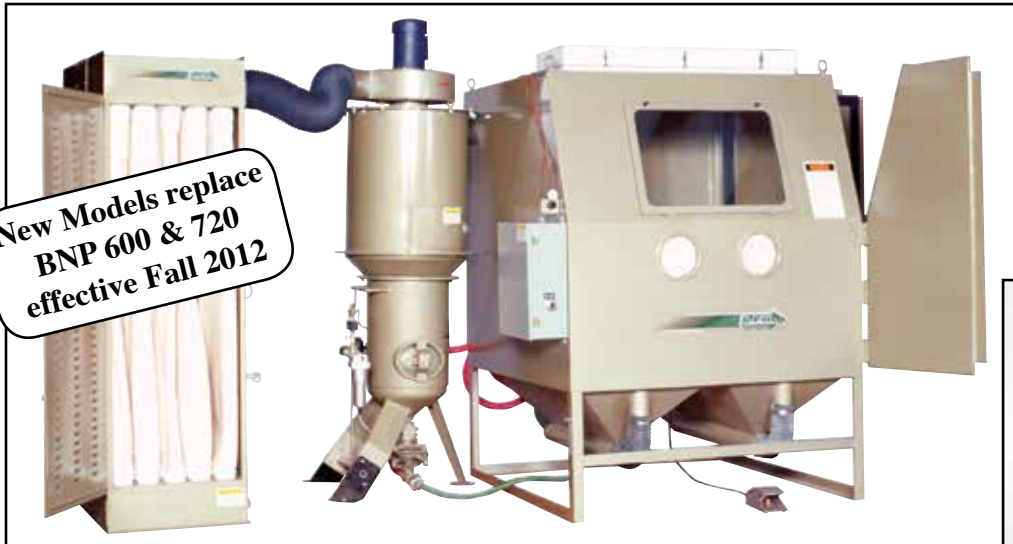

## BNP 6012 & 7212 Mini Blast Rooms - Pressure System



**New Models replace  
BNP 600 & 720  
effective Fall 2012**

**Clean  
Peen  
Deburr  
Finish**

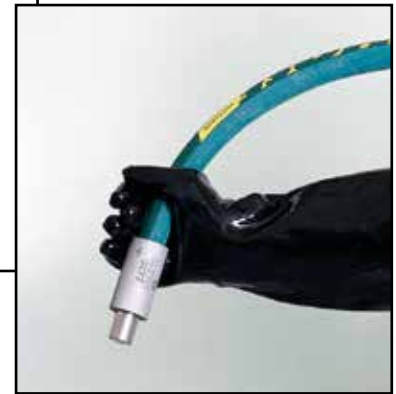

Model BNP-6012 with 900 CFM Reclaimer and Dry Filter Dust Collector

**For tough cleaning jobs, pressure blasting delivers higher abrasive velocity for greater impact intensity, compared to suction blasting, and can increase your production rate by as much as 300 percent.**

New — bolt-on sump pipes and pipe adaptors, and dimensional changes that affect curtain sizes.  
**CAUTION:**  
Curtain sizes differ; take care when ordering replacement curtains or alox kits for older 600 and 720 models.

### Common Applications

- Remove rust, mill scale, heat scale, and carbon buildup from metals
- Strip paint, powder coating, plating, and anodizing from parts for rework
- Eliminate burrs, parting lines, flashings, and other defects from castings and injection-molded parts
- Extract residual sand from castings
- Beautify steel, stainless steel, aluminum, brass and other metals with a uniform matte finish
- Etch artwork and lettering into glass, stone, plastics, metal and other materials
- Clean release agents and material buildup from molds

### BNP 6012/7212 Pressure Cabinets Feature: Safety

- ✓ Full-length, neoprene-on-fabric gloves resist wear and protect operator.
- ✓ Ceiling-mounted, four-tube fluorescent light fixture with abrasive resistant wire-embedded glass cover for extraordinary visibility.
- ✓ Safety interlocks interrupt blasting if either door is opened.
- ✓ Heavy-duty, cam-style latch seals doors tight through years of service.

### Productivity

- ✓ High efficiency, 2.0 cubic foot capacity, ASME-coded pressure vessel, fitted with 1" ID piping, industrial-quality blast hose and couplings and cabinet integrated controls.
- ✓ Unique Air Logic system (pilot actuated) to maximize air flow to the nozzle.
- ✓ Double-wall, sound-insulated doors.
- ✓ 12-gauge steel all-welded construction, with strength breaks to form a rigid, long-lasting cabinet shell.
- ✓ Large 20" x 30" view window.

### Convenience

- ✓ Tilt-out window, for tool-free glass changes in minutes.
- ✓ Pressure regulator, gauge, and electric switch mounted within easy reach.
- ✓ Built-in blow-off gun helps keep dust inside the cabinet, not on your floor.
- ✓ Bolt-on sump pipes allow easy replacement for maintenance or conversion for use with steel media.

### Tungsten Carbide Blast Nozzle

The standard No 3 tungsten carbide nozzle is perfect for most blasting, while the optional boron carbide nozzles stand up to hundreds of hours of blasting with aluminum oxide or other aggressive abrasives.

### Popular Accessories

- Adjustable vortex cylinder—recommended for light weight media (standard on RP collectors)
- Air-powered vertical lift door
- Alox kit (for harsh, media)
- Metallic media kit
- Curtains (black or high-visibility white)
- HEPA filter (RP model only)
- Manometer kit
- Oscillator assembly
- Timed door release
- 36", 40, and 48" Dia. turntables
- Work car & track assembly
- Additional operator station
- Additional door set

# S P E C I F I C A T I O N S

## COMPLETE SYSTEM

Actual space required depends on equipment configurations, options and desired work flow. Allow additional work space for operator and maintenance access.

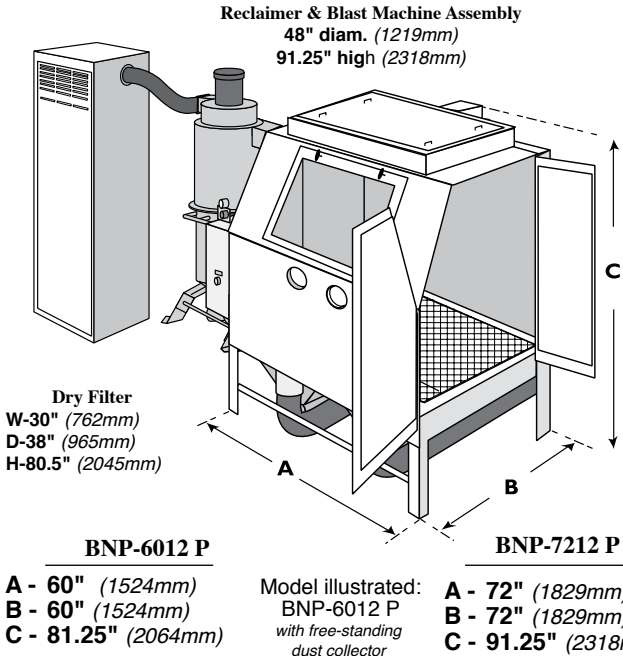

## BLAST/ RECLAIM SYSTEM

### The Heart of ZERO's Blasting System

Our exclusive media reclaimers continuously extract dust and debris and return properly sized, usable media to the blast system. The standard reclaimer handles all non-metallic media. For metallic media, specify reduced ID conveying hose.

The versatile design of our larger reclaimers lets you quickly adapt the system to your changing needs - add media hoppers, rubber liners, or pull-through dust-collection.

The reclaimer, mounted atop the pressure vessel, automatically re-fills the blast system with clean, recycled media.

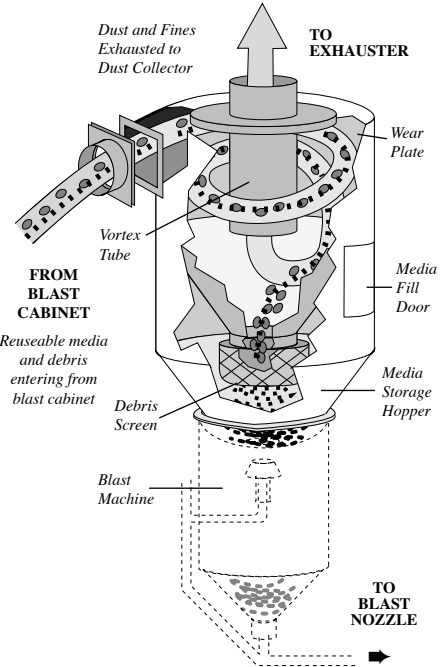

## CABINET

### Working Chamber Size

**BNP-6012 P** 58" wide (1473 mm)  
58.5" deep (1486 mm)  
53" high (1346 mm)

**BNP-7212 P** 69" wide (1753 mm)  
70.5" deep (1778 mm)  
63" high (1600 mm)

### Window Size (safety glass)

30" wide (762 mm)  
20" high (508 mm)

Door interlock system conforms to U.S. government regulations.

### Door Opening

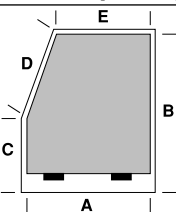

**BNP-6012 P**    **BNP-7212 P**

**A - 55.5"** (1410 mm)    **67"** (1702 mm)  
**B - 52.5"** (1333 mm)    **63.5"** (1613 mm)  
**C - 27"** (686 mm)    **28"** (711 mm)  
**D - 27"** (686 mm)    **38"** (965 mm)  
**E - 46"** (1168 mm)    **54"** (1372 mm)

## DUST COLLECTORS

Dry filters are suitable for most industrial applications where the dust collector can be shut off periodically to shake dust from the 100% cotton sateen filter tubes.

Dry filters trap 98% of dust down to 1.0 micron.

Reverse pulse cartridge dust collectors (which trap 99.7% of dust down to 0.5 micron) allow non-stop, high-production blasting. The polyester-cellulose cartridges are automatically pulse cleaned for maximum filter efficiency. Worn cartridges can be replaced in minutes.

Dry Filters	Reverse Pulse Collector
5 sq ft filter area per tube 900 cfm DF has 40 tubes (200 sq ft)	235 sq ft filter area per cartridge RPC-2 has 2 cartridges (470 sq ft) RPH-3 has 3 cartridges (705 sq ft)

Clemco is committed to continuous product improvement. Specifications are subject to change without notice. ISO 9001:2008 certified.

## NOZZLES

### AIR REQUIREMENTS

NOZZLE	NOZZLE ORIFICE	CFM at 80 PSI	M <sup>3</sup> /Min at 5.5 BAR	CFM at 100 PSI	M <sup>3</sup> /Min at 7 BAR
No. 3	3/16"	38	1,08	45	1,3
No. 4	1/4"	68	1,93	81	2,3*
No. 5	5/16"	113	3,20	137	4,0

\* For nozzles larger than #4 the recovery size may need to be increased. BNP Mini Blast Rooms are furnished with a No. 3 tungsten carbide nozzle.

## ELECTRICAL

**900 CFM** (25 m<sup>3</sup>/m) 2HP, 3PH, 60HZ, (1.5KW, 220V, 3PH, 50HZ.);  
**1200 CFM** (34 m<sup>3</sup>/m) 5HP, 3PH, 60HZ, (3.7KW, 220V, 1PH, 50HZ.);  
available with three phase motors only.

Other motors and electrical configurations are available to make your system compatible with local power systems.

## ORDERING INFORMATION

Model Number	Reclaim CFM (m <sup>3</sup> /m)	Dust Coll.	230V Stk. No.	460V Stk. No.	Ship Wt. (lb/kg)
<i>Note: 1200 cfm reclaim or larger is required for metallic media</i>					
BNP-6012P-900 DF	900 (25)	Dry Filter	25477	25478	2,569 (1168)
BNP-6012P-900 RPC	900 (25)	RPC-2	25481	25482	2,849 (1295)
BNP-6012P-900 RPH	900 (25)	RPH-2	25485	25486	3,424 (1556)
BNP-6012P-1200 RPH	1200 (34)	RPH-3	25489	25490	4,115 (1870)
BNP-6012PM-1200 RPH	1200 (34)	RPH-3	27460	27461	4,115 (1870)
BNP-7212P-900 DF	900 (25)	Dry Filter	25503	25504	3,125 (1420)
BNP-7212P-900 RPC	900 (25)	RPC-2	25507	25508	3,405 (1548)
BNP-7212P-900 RPH	900 (25)	RPH-2	25511	25512	3,980 (1809)
BNP-7212P-1200 RPH	1200 (34)	RPH-3	25515	25516	5,025 (2284)
BNP-7212PM-1200 RPH	1200 (34)	RPH-3	27462	27463	5,025 (2284)