

BNP 6012P and 7212P Pressure Blast Cabinets O. M. 27724

**DATE OF ISSUE: 12/13
REVISION:**

NOTICE TO PURCHASERS AND USERS OF OUR PRODUCTS AND THIS INFORMATIONAL MATERIAL

Clemco proudly provides products for the abrasive blast industry and is confident that industry professionals will use their knowledge and expertise for the safe and efficient use of these products.

The products described in this material, and the information relating to these products, are intended for knowledgeable, experienced users. It is the responsibility of the user to insure that proper training of operators has been performed and a safe work environment is provided.

No representation is intended or made as to: the suitability of the products described here for any purpose or application, or to the efficiency, production rate, or useful life of these products. All estimates regarding production rates or finishes are the responsibility of the user and must be derived solely from the user's experience and expertise, not from information contained in this material.

It is possible that the products described in this material may be combined with other products by the user for purposes determined solely by the user. No representations are intended or made as to the suitability of or engineering balance of or compliance with regulations or standard practice of any such combination of products or components the user may employ.

This equipment is only one component of a cabinet blasting operation. Other products, such as air compressors, air filters and receivers, abrasives, equipment for ventilating, dehumidifying, or other equipment, even if offered by Clemco, may have been manufactured or supplied by others. The information Clemco provides is intended to support the products Clemco manufactures. Users must contact each manufacturer and supplier of products used in the blast operation for warnings, information, training, and instruction relating to the proper and safe use of their equipment.

© 2013 CLEMCO INDUSTRIES CORP.
One Cable Car Dr.
Washington, MO 63090
Phone (636) 239-4300
Fax (800) 726-7559
Email: info@clemcoindustries.com
www.clemcoindustries.com



1.0 INTRODUCTION

1.1 Scope of Manual

1.1.1 These instructions cover set-up, operation, maintenance, troubleshooting, optional accessories, and replacement parts for BNP 6012 and 7012 series pressure blast cabinets with all reclaimer, dry filter and dust collector options. Supplemental manuals are provided for the Sentinel media metering valve and optional reverse pulse dust collector.

1.1.2 These instructions contain important information required for safe operation of the cabinet. Before using this equipment, all personnel associated with the blast cabinet operation must read this entire manual, and all accessory manuals to become familiar with the operation, parts and terminology.

1.2 Safety Alerts

1.2.1 Clemco uses safety alert signal words, based on ANSI Z535.4-2011, to alert the user of a potentially hazardous situation that may be encountered while operating this equipment. ANSI's definitions of the signal words are as follows:



This is the safety alert symbol. It is used to alert you to potential physical injury hazards. Obey all safety messages that follow this symbol to avoid possible injury or death.

NOTICE

Notice indicates information that is considered important, but not hazard-related, if not avoided, could result in property damage.

CAUTION

Caution indicates a hazardous situation that, if not avoided, could result in minor or moderate injury.

WARNING

Warning indicates a hazardous situation that, if not avoided, could result in death or serious injury.

⚠ DANGER

Danger indicates a hazardous situation that, if not avoided, will result in death or serious injury.

1.3 General Description

1.3.1 BNP abrasive blast cabinets enclose the blasting environment to provide efficient blast cleaning while maintaining a clean surrounding work area. Production rates are influenced by size of nozzle, compressor output, working pressure, type and size of media, angle and distance of the nozzle from the blast surface. BNP pressure cabinets consist of four major components:

1. Cabinet Enclosure
2. Reclaimer
3. Blast Machine
4. Dust Collector

Refer to Figure 1 for arrangement of components using a dry filter dust collector. Figure 2 shows the arrangement with an RPC-2 reverse-pulse dust collector with dust drawer.

An optional RPH-2 collector is set up the same way but includes a hopper that is easier to empty and has additional storage. Upgrading to an RPH-2 collector may be done at any time. The overall height of the RPH-2 is approximately 10-feet, 4-inches, increases to 12-ft when the top access door is open. RPH dust collectors are standard with systems requiring 1200 cfm and larger dust collectors.

1.4 Theory of Operation

1.4.1 When the cabinet is correctly setup and ready for operation, the operator steps on the foot pedal to activate the blast machine. Fully depressing the foot pedal pressurizes the blast machine, causing the media to be propelled through the blast hose and out the nozzle. After striking the object being blasted, the media, along with fines, dust, and by-products generated by the process, fall through the mesh worktable into the cabinet hoppers. These particles are then drawn into the reclaimer for separation. Dust and fines are first separated from reusable media and go into the dust collector. Next, the media is screened for oversize particles, and returned to the reclaimer hopper (and blast machine head) for reuse. Dust and fines entering the dust collector are removed from the air stream as they pass through the filters, discharging clean air. When the foot pedal is released, blasting stops, the blast machine depressurizes, and stored media refills the machine.

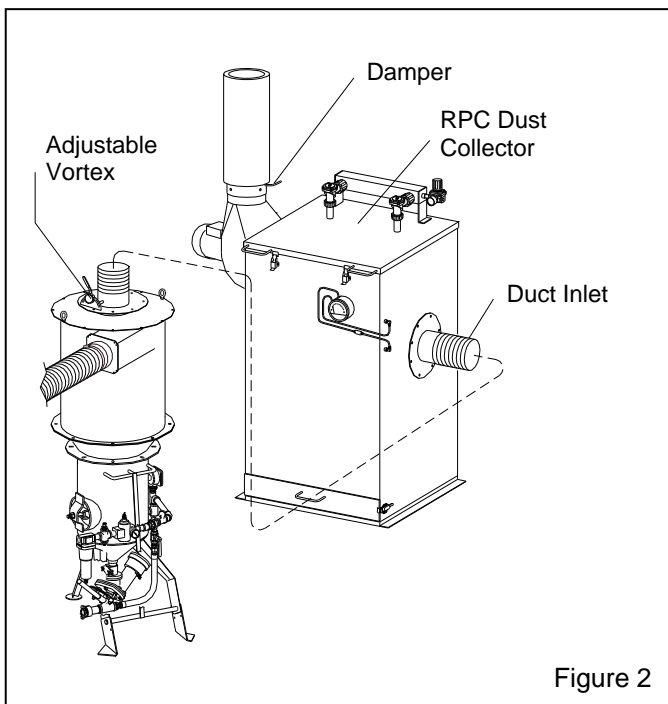
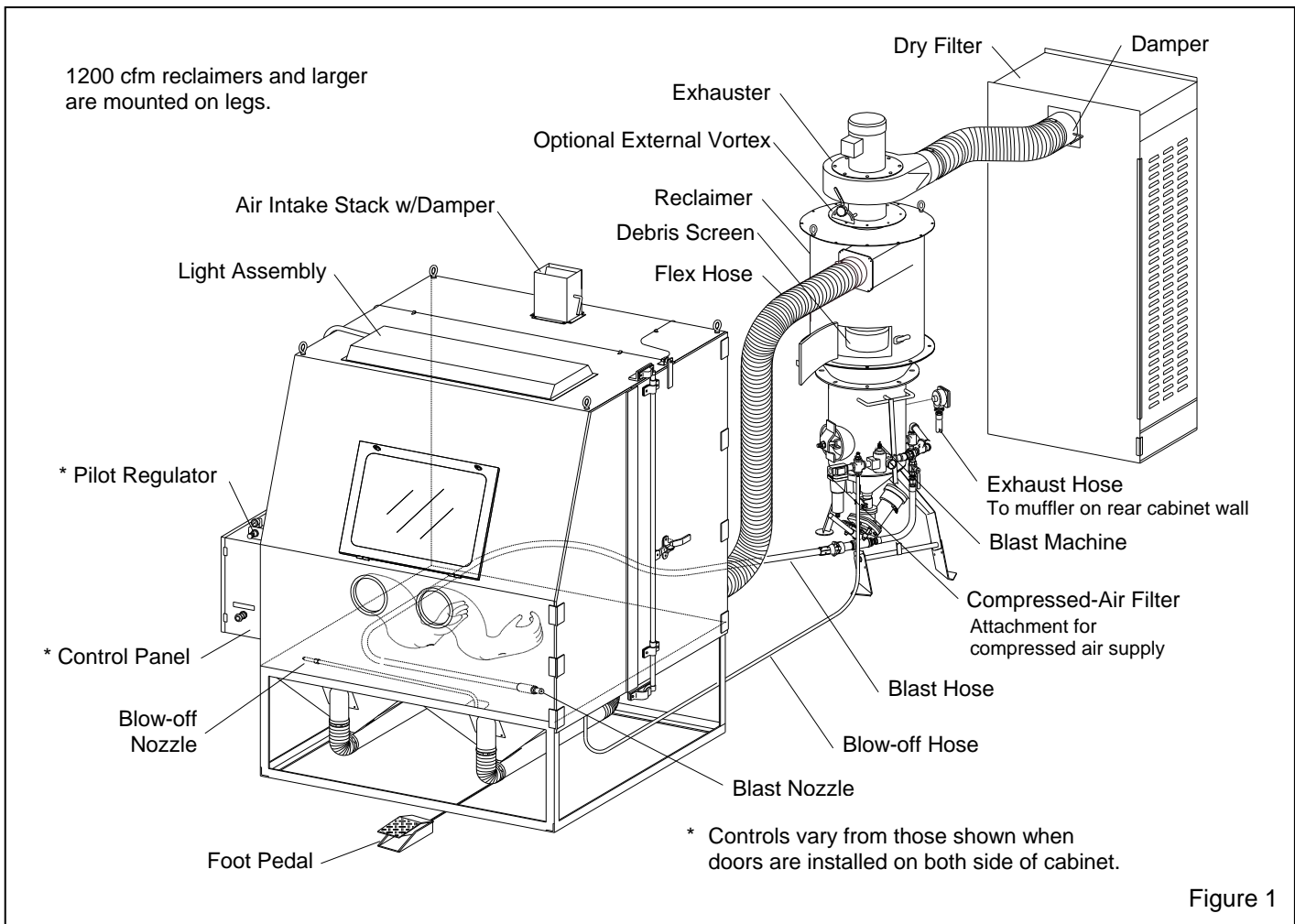

1.5 Blast Machine and Remote Controls

1.5.1 The blast machine pressure vessel is manufactured to American Society of Mechanical Engineers (ASME) standards, as described in Section VII, Div. 1, and carry National Board certification. It is the owner's responsibility to maintain the integrity of the vessel as may be required by some states. This may include regular inspection and hydrostatic testing as described in National Board Inspection Code and Jurisdictional Regulations and /or Laws.

⚠ WARNING

Welding, grinding, or drilling on the blast machine could weaken the vessel. Compressed air pressure could cause a weakened vessel to rupture, resulting in death or serious injury. Welding, grinding, or drilling on the blast machine vessel, without a National Board "R" stamp, voids the ASME and National Board certification.

1.5.2 All welding repairs done on the vessel must be performed by certified welders, at shops holding a National Board "R" Stamp. Welding performed by any welder not properly qualified per the ASME Code voids ASME and National Board certification of the vessel.

1.5.3 Do not exceed the maximum working pressure rating (PSI) of the blast machine. The maximum pressure rating is stamped into the National Board Label which is welded onto the side of the vessel.

WARNING

Excessive compressed air pressure could cause the vessel to rupture. To prevent serious injury or death, do not exceed the rated pressure of the vessel.

1.5.4 OSHA does not require pressure relief valves on blast machines when air compressors supplying air to the blast machines are built to ASME⁽¹⁾ specifications and comply with OSHA⁽²⁾ regulations. ASME Manual section VIII, Division 1, UG-125, paragraph A90 (g) states that pressure relief valves or protective devices **"...need not be installed directly on a pressure vessel when the source of pressure is external to the vessel and is under such positive control that the pressure in the vessel cannot exceed the maximum allowable working pressure at the operating temperature..."**. OSHA regulation 1910.169 refers to the above ASME code when describing the necessity of pressure relief valves on compressed air equipment. **DO NOT** operate blast machines with air compressors that are not equipped with properly functioning pressure relief valves.

⁽¹⁾ American Society of Mechanical Engineers, Boiler and Pressure Vessel Code, 1989

⁽²⁾ Occupational Safety and Health Administration, 29 CFR 1910, Subpart M - Compressed Gas and Compressed Air Equipment.

1.5.5 When the cabinet is setup and operational, the blast machine is ready for actuation by the foot pedal. Pressing the foot pedal opens the normally closed inlet valve, and closes the normally open outlet valve. The incoming air pressurizes the media chamber, and blasting begins. When pressure on the foot pedal is released, the chamber depressurizes, and blasting stops.

1.6 Reclaimer Options

- **Push-Thru:** Motor mounted on Reclaimer pushes ventilation/recovery air thru dry filter.
- **Pull Thru:** Motor mounted on dust collector pulls ventilation/recovery air thru reclaimer.

1.6.1 900 cfm reclaimers are available on standard cabinets using a dry filter, RPC-2, or RPH-2 dust collector. 1200 cfm reclaimers are available on standard cabinets with an RPH-3 dust collector. 1800 cfm reclaimers are available on special order. Refer to Figure 4 for 1800 cfm applications.

1.6.2 Replaceable rubber reclaimer liners prolong service life of the reclaimer, and should be installed when using aggressive media. Rubber liners are shown in Section 9.11.

1.7 Nozzle Options

1.7.1 Unless otherwise specified at the time of order, cabinets are shipped with a 3/16" (#3) orifice, tungsten carbide nozzle. Optional 1/8", 1/4", and 5/16" orifice nozzles are also available. The reclaimer size determines the maximum allowable nozzle size. The chart in Figure 3 shows the maximum nozzle size recommended under normal conditions. Normal conditions are moderate part contamination, media break down, media flow, media size, and damper setting, and are further explained within the contents of the manual.

RECLAIMER SIZE	MAXIMUM NOZZLE SIZE
900 cfm	1/4" orifice
1200 cfm	5/16" orifice
1800 cfm	5/16" orifice

NOTICE

Nozzles larger than 1/4" will substantially increase wear on standard 1/2" ID blast hose. Optional 3/4" Supa hose should be used with 5/16" nozzles.

Figure 3

1.7.2 Nozzles with an orifice larger than those recommended could cause air leakage from the cabinet and impair recovery from the cabinet hopper. 5/16" orifice nozzles will substantially increase wear on 1/2" blast hose. Use optional 3/4" Supa hose with 5/16" nozzles. See Optional Accessories in Section 9.1.

1.7.3 Use boron carbide nozzles when blasting with aggressive media such as aluminum oxide or silicon carbide. Refer to Optional Accessories in Section 9.1.

1.8 Dust Collector Options

WARNING

Prolonged exposure to any dust could result in serious lung disease and death. Short term ingestion of toxic materials, such as lead dust or dust from other heavy metals and corrosives, could cause serious respiratory injury or death. Identify all materials that are to be removed by blasting. Use reverse-pulse dust collectors with HEPA after-filters if lead coating or any other toxic materials are being removed by the blasting process. Do not use dry filter dust collectors for those applications.

1.8.1 Dry Filter: A push-through dry filter (where the motor is mounted on the reclaimer) uses tubular filters which trap dust on their inner surfaces. A dry filter is efficient for use with 900 cfm reclaimers, and moderate dust contamination. The filters must be manually shaken at least every two hours and the dust drawer emptied regularly. This type of dust collection must never be used in applications which generate toxic dust.

1.8.2 Reverse Pulse Dust Collector: A pull-through reverse-pulse dust collector (where the motor is mounted on the dust collector) is the most efficient dust collector option. Cartridge filters are automatically cleaned by a periodic pulse of compressed air. This type of dust collector used with the optional HEPA filter must be used in applications in which toxic dust is generated. A separate manual is provided with the reverse-pulse dust collectors.

1.8.3 HEPA Filter: HEPA filters must be used when removing lead coatings or any other toxic materials. Optional HEPA after-filters provide additional filtration, and are available for use with a reverse-pulse collector. See Optional Accessories, Section 9.1.

1.9 Metering Valve Options

1.9.1 Unless otherwise specified at the time of order, cabinets are shipped with a fine-mesh Sentinel metering valve. The valve is for use with 50 mesh and finer media, and #10 and finer glass bead. The optional Sentinel metering valve is for use with 50-mesh and coarser media. Conversions kits easily convert the valves either way. Kits are listed in Section 9.1.

1.10 Blasting Media

1.10.1 ZERO cabinets utilize most common reusable media specifically manufactured for dry blasting. Media sizes shown in Figure 4 are for guidelines only. The

guidelines are based on standard nozzle size and average conditions, such as blast pressure, media/air mixture, visibility inside the cabinet, humidity, and reclaimer cleaning rate.

Several factors affecting the reclaimer cleaning rate include: reclaimer size (cfm), contamination of parts being cleaned, media friability, damper setting (static pressure), type of dust collection, dust collector filter loading (differential pressure across the dust filters).

As a rule, larger nozzles deliver more media, requiring higher performance from the reclaimer. Larger nozzles decrease the maximum mesh size of media from those normally recommended. On the other hand, leaner media flow and lighter or less dense media can increase the maximum usable media size. Media that is finer than those recommended may decrease visibility in the cabinet, and increase carryover to the dust collector. Media coarser than those recommended may be too dense for the reclaimer to recover from the cabinet hopper.

1.10.2 Steel: When the recovery hose diameter is suitably sized (usually reduced one size from standard) steel may be used with 900 cfm and larger reclaimers on single hopper cabinets and 1200 cfm and larger reclaimers with double hopper cabinets. When using steel media, conveying hose should have a smooth durable lining, and rubber curtains should be used to protect the cabinet walls from peening and rapid wear. Cabinets configured for steel media use can be ordered from the factory with appropriately sized conveying hose and curtains installed.

1.10.3 Sand and Slag: Sand should NEVER be used because of the respiratory hazards associated with media containing free silica. Slags are not recommended because they rapidly breakdown and are not recyclable, making them unsuitable for cabinet applications.

1.10.4 Silicon Carbide, Aluminum Oxide, and Garnet: These are the most aggressive of the commonly used media. These may be used, but the service life of any equipment components which come in contact with the media will be reduced. To avoid unscheduled down time, periodically inspect the reclaimer wear plate, exhaust housing and paddle wheel, blast hose, and nozzle for wear.

When using aggressive media only occasionally, install an optional aluminum oxide kit. When these media are used extensively, use a full rubber-lined reclaimer and a reverse pulse dust collector. Interior rubber curtains in the cabinet are suggested. Nozzles lined with boron carbide will extend nozzle wear life. See Optional Accessories in Section 9.1.

This guideline to media sizes is based on standard 3/16" orifice nozzle (3/8" with plastic and similar weight media blasting at low pressure) and average conditions, such as air pressure, media/air mixture, visibility, contamination of parts being cleaned, humidity, media friability, reclaimer cleaning rate, etc. As a rule, larger nozzles deliver more media, requiring higher performance from the reclaimer. Larger nozzles decrease the maximum mesh size of media from those recommended. Media that is finer than those recommended may decrease visibility, and at some point carryover to the dust collector. Media coarser than those recommended may be too dense for the reclaimer to recover from the cabinet hopper.

RECLAIMER SIZE	MEDIA TYPE				
	STEEL GRIT	STEEL SHOT	PLASTIC	GLASS BEAD	ALUM. OXIDE
900 cfm with 6" inlet	Do not use	Do not use	12 to 40 mesh	No. 8 to No. 12	54 to 180 mesh
1200 cfm with 6" inlet	50 to 120	S230 to S70	Do not use	No. 4 to No. 8	16 to 60 mesh
1200 cfm with 7" inlet	Do not use	Do not use	12 to 40 mesh	No. 4 to No. 12	46 to 180 mesh
1800 cfm with 7" inlet	25 to 120	S280 to S70	Do not use	No. 4 to No. 8	16 to 60 mesh
1800 cfm with 8" inlet	Do not use	Do not use	12 to 40 mesh	No. 4 to No. 12	36 to 180 mesh

Figure 4

1.10.5 Glass Bead: Most beads are treated to ensure free-flow operation even under moderately high humidity conditions. Glass beads subjected to excessive moisture may be reused only after thorough drying and breaking up any clumps.

1.10.6 Fine-mesh Media: An optional, adjustable vortex cylinder should be installed when using 180-mesh and finer media. NOTE: The vortex cylinder is standard on new cabinets with reverse-pulse dust collectors (pull-through systems). When using 180 mesh and finer media, the inlet baffle of the reclaimer may need to be removed. Contact Clemco Customer Service before proceeding with removal of the baffle.

1.10.7 Lightweight Media: An optional adjustable vortex cylinder should be installed when using lightweight media and most agricultural media. NOTE: The vortex cylinder is standard on new cabinets with reverse-pulse dust collectors (pull-through systems). When using lightweight media, the inlet baffle of the reclaimer may need to be removed. Contact Clemco Customer Service before proceeding with removal of the baffle.

1.10.8 Plastic Media: Plastic and similar media requires a blast machine with a 60 degree conical bottom. Refer to Clemco's Aerolyte line.

1.11 Compressed Air Requirements

1.11.1 The size of the compressor required to operate the cabinet depends on the size of the nozzle and blasting pressure. The table in Figure 5 shows air

consumption of nozzles when new. It does not show the recommended compressor size. As nozzles wear, they will consume up to 70% to 80% more air. Consult with a compressor supplier for a suggested compressor size based on the maximum air consumption.

NOTE: A separate air line is required for the optional reverse-pulse dust collector.

Nozzle size	Air Pressure (psi)			
	50	60	70	80
1/8"	11	13	15	17
3/16"	26	30	33	38
1/4"	47	54	61	68
5/16"	77	89	101	113

* Figures are approximate and for reference only, and may vary for different working conditions. Several variables, including media flow and nozzle wear affect cfm consumption.

Figure 5

1.11.2 The air filter at the blast machine inlet, removes condensed water from compressed air. Its use is especially important in areas of high humidity, or when fine-mesh media are used. Moisture causes media to clump and prevents free flow through the metering valve. If moisture problems persist, an air dryer may be required.

1.12 Electrical Requirements

1.12.1 Exhauster motors used with 6012 and 7212 cabinets are 230/460 volt, 3-Phase, 60 Hz.

1.12.2 A control panel and starter are provided with 230-volt controls unless 460-volt is specified on the order. Power from the user's disconnect has to be wired to it. Additional wiring information is in Section 2.11. A wiring schematic is enclosed in the control panel.

2.0 INSTALLATION

2.1 General Installation Notes

2.1.1 To avoid damage to the light assembly and air intake stack, they are shipped inside the cabinet. Install the light assembly and intake stack on the outside top of the cabinet (ref Figure 1), using the adhesive backed gasket and fasteners provided. Install the light conduit and wiring to the control panel, and wire it per the wiring schematic packed in the panel. Refer to Section 2.11.

WARNING

Use an approved ladder or lift when installing or servicing the light assembly or air intake stack. Do not climb on top of the cabinet. The cabinet top will not support body weight and could cause injury.

2.1.2 The cabinet must be placed on a flat level surface. If the surface is not flat, the cabinet could flex, causing the door alignment to shift. If the floor is not level, shim the leg(s) as required to align the doors.

2.1.3 Refer to Figure 1 (and 2 for optional reverse pulse collector) for the general arrangement. Select a location where compressed air and electrical service are available. The cabinet location must comply with OSHA and local safety codes. Allow for full access to all doors and service areas, and for efficient handling of large parts. Provide enough clearance in front of the dust collector to remove the dust drawer without tipping. Ideally, locate the blast machine directly behind the cabinet with the blast hose connection facing toward the cabinet. The reclaimers may be rotated on the blast machine to enable hose connections with as few bends as possible. Determine the best location, and position all units before final assembly.

2.1.4 Use the eyebolts on the four top corners to lift and maneuver the cabinet. **Do not lift the cabinet from the hopper or lower frame.**

NOTICE

Do not use a forklift to lift the cabinet from the hoppers or lower frame. The cabinet hopper is not designed to support the weight of the cabinet. The lower frame is designed to support distributed weight. Using a forklift on the hoppers or frame may cause damage.

2.2 Assemble Blast Machine and Reclaimer

2.2.1 Apply adhesive-backed strip gasket to the top of the flange on the blast machine. Punch out an opening at each bolt hole.

2.2.2 If the optional storage segment is used, place it on the blast machine. The access door should be on the bottom, and rotated to allow access. Bolt into place. Apply adhesive backed gasket to the top flange as described in Section 2.2.1

2.2.3 Use a lift to raise the reclaimer over the blast machine assembly, and lower it in place. Attach with fasteners provided. **Note: 1200 cfm and larger reclaimers are mounted on legs. Slide the blast machine under the reclaimer and bolt flanges together.**

WARNING

Do not work under the reclaimer while it is hanging from the lifting device. Severe injury or death could occur if the reclaimer is released before it is secured to the blast machine.

2.3 Support the Blast Machine

2.3.1 Use chain, cable, or other means to temporarily support the blast machine and reclaimer during final assembly.

2.4 Connect Conveying Hose, Figure 6

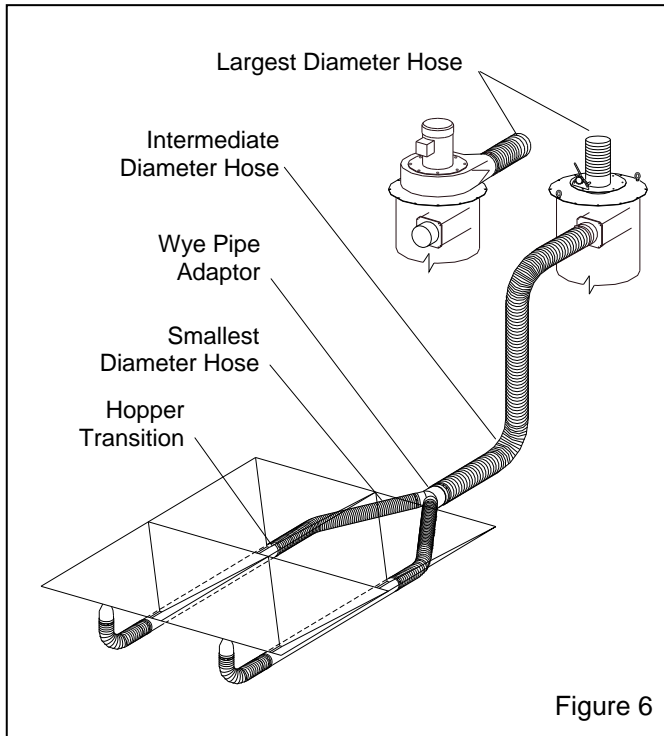

2.4.1 Connect the two smallest diameter flexible conveying hoses between the cabinet hopper transitions and wye pipe adaptor. It is easier to slip the hose over the adaptor and to create a tighter seal if the first two or three inches of wire are removed from the inside of the hose. Use care not to damage the hose. NOTE: The hose wire helps dissipate static electricity in the conveying hose, and also helps ground each segment. In order for the hose wire to dissipate static electricity, the wire must touch the metal of each segment. Clamp the flex hose securely with worm clamps provided.

2.4.2 Connect the intermediate diameter flex hose between the wye pipe and reclaimer inlet adaptor. Clamp the flex hose securely with worm clamps provided.

2.4.3 The largest diameter hose attaches to the reclaimer outlet, which will be connected later.

2.5 Connect Blow-Off Hose

2.5.1 Attach the 1/2" blow-off hose coming from the front right cabinet hopper to the compatible fitting on the blast machine piping, between the air filter and regulator. Refer to the schematic in Figure 7.

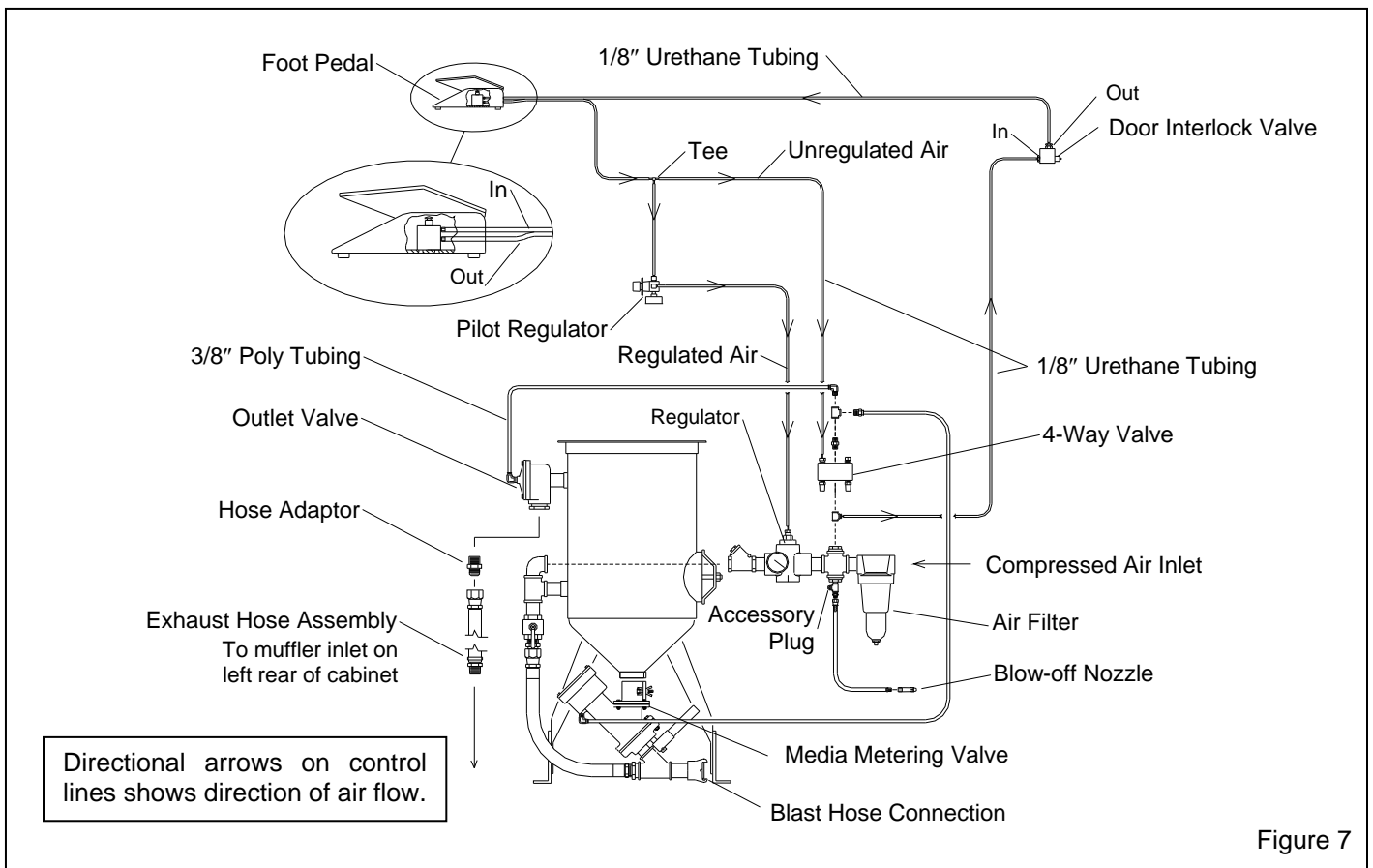

2.6 Connect Blast Hose

WARNING

Hose disconnection while under pressure could cause serious injury. Use safety lock-pins and safety cables on all coupling connections to help prevent hose couplings from accidental disconnection while under pressure. Lock-pins and safety cables are listed under Optional Accessories in Section 9.1.

2.6.1 Connect the blast hose from the lower left side of the rear cabinet wall to the coupling at the bottom of the blast machine. Be sure coupling gaskets are in place and couplings are secured with safety lock-pins.

2.7 Attach Air Exhaust Hose

2.7.1 Screw the male end of the exhaust hose into the 1" coupling in the lower left side of the rear cabinet wall. Connect the female swivel end to the adaptor on the blast machine outlet valve.

2.8 Connect Urethane Control Tubing

2.8.1 Uncoil the 1/8" urethane control tubing, from under the cabinet. The end of each tubing is numbered 1, 2, 3 or 4. Connect the tubing to the adaptor with the corresponding number on the pressure regulator, piping, and 4-way air valve. Check the schematic in Figure 7 to confirm the connections.

2.9 Connect Compressed Air Supply Line(s)

WARNING

Failure to observe the following before connecting the equipment to the compressed air source could cause serious injury or death from the sudden release of compressed air.

- **Lockout and Tagout the compressed air supply.**
 - **Bleed the compressed air supply line.**
-

WARNING

To avoid the risk of injury from compressed air, install an isolation valve and bleed-off valve where the air supply is tapped into the compressed air system. This enables depressurization of the compressed air circuit before performing maintenance.

2.9.1 Install an air fitting to the compressed-air filter at the blast machine inlet that is compatible with the compressed-air supply hose. See Section 2.9.2

2.9.2 Install an isolation valve at the air source to enable depressurization for service. Connect a 1" ID or larger air line from the air source to the air filter. A smaller diameter hose may reduce blasting efficiency.

NOTE: A separate air line is required for the optional reverse pulse dust collector.

WARNING

If twist-on type air hose couplings are used, they must be secured by safety pins or wires to prevent accidental disconnection while under pressure. Hose disconnection while under pressure could cause serious injury.

2.10 Ground Cabinet

2.10.1 To prevent static electricity build up, attach an external grounded wire from an earth ground to the grounding lug on the left rear of the cabinet.

2.11 Connect Three Phase Electrical Service

WARNING

Lockout and Tagout the electrical supply before performing any electrical service. Shorting electrical components could result in death, serious injury from electrical shock, or equipment damage. All electrical work, or any work done inside an electrical panel, must be performed by qualified electricians, and comply with applicable codes.

2.11.1 The choice of 230 or 460 voltage must be made at time of order, so that control panels and wiring are supplied accordingly. The electrician only needs to wire connection from the light to the panel (refer to Paragraph 2.1.1), provide service to the motor starter in the electrical panel mounted on the cabinet and connection of the conduit, and wiring from the starter to the motor. Refer to the wiring schematic packed inside the panel. NOTE: The user must provide conduit and wiring from the starter to the motor for optional reverse pulse dust collectors.

NOTE: After wiring is completed, keep a copy of the schematic with the manual for service and electrical replacement parts.

2.11.2 Where possible, all wiring has been completed at the factory. Conduit and wire are supplied from the cabinet control panel for wiring 900 cfm reclaimer motors when used with dry filter collectors. Larger reclaimers and reclaimers used with reverse pulse dust collectors are usually too far from the cabinet to use flex. NOTE: The user must provide conduit and wiring from the starter to the motor for reverse-pulse collectors. Wiring from the user's disconnect to the cabinet control panel must also be provided by the user.

2.11.3 Connect flex conduit, and wire the motor per instruction on the motor plate.

2.11.4 Supply service from the user's disconnect to the control panel, as shown on the wiring schematic.

2.11.5 Connect the ground wire to the grounding lug as shown on the schematic.

2.11.6 After the wiring is completed, observe the following warning, and check the motor rotation. To check rotation, jog the starter (momentarily turn switch on and off). This will cause the motor to rotate slowly. Look through the slots in the fan housing on top of the motor where rotation of the fan can easily be observed. Proper rotation is indicated by the arrow on the exhaust housing. The fan should rotate toward the exhaust outlet.

WARNING

Do not look into the exhaust outlet while the paddle wheel is turning. Injury to the eye or face could occur from objects being ejected from the exhauster.

2.11.7 Check the amperage on initial start up. If the motor draws excessive amperage, gradually close the damper until the amperage is within the specifications shown on the motor plate. The damper is located on the inlet of dry filters, and on the exhaust outlet of reverse-pulse dust collectors.

2.12 Dry Filter Dust Collector (900 cfm only). See separate manual for Reverse Pulse Dust Collector.

2.12.1 Dry filters can be converted to left or right hand inlet. If it is more convenient to have the inlet on the opposite side, switch the inlet adaptor for the blank cover.

2.12.2 Connect the flexible exhaust hose between the reclaimer outlet and dry filter inlet. It is easier to slip the hose over the adaptors, and create a tighter seal if the first two or three inches of wire are removed from the

inside of the hose. Use care not to damage the hose. Secure the hose with worm clamps. NOTE: The hose wire helps dissipate static electricity in the conveying hose, and also helps ground each segment. In order for the hose wire to dissipate static electricity, the wire must touch the metal of each segment.

2.13 Anchor Blast Machine

2.13.1 When all the components are in their permanent positions, remove the temporary supports, and bolt the blast machine to the floor. Anchor holes are located in the blast machine leg pads. Anchor through the holes to secure the machine to the floor.

2.14 Intake Stack with Damper

2.14.1 The inlet damper must be set to match the cabinet dimensions and reclaimer size. The decal on the damper shows the settings in degrees. The initial settings are as follows:

900 reclaimeralign handles to 30 degrees
1200 reclaimer align handles to 0 degree (full open)
1800 reclaimer align handles to 0 degree (full open)

Refer to Section 5.6 for adjustment procedure.

2.14.2 Loosen the lock nuts and position the damper. When correctly positioned, tighten the lock nuts to maintain the setting.

2.15 Final Assembly

2.15.1 Position the foot pedal on the floor at the front of the cabinet or on the foot shelf on ergonomic models.

2.15.2 A package of 5 cover lenses is supplied with the cabinet. To install a cover lens, remove the adhesive backing and apply the lens to the clean, dry, inner surface of the view window per Section 6.2. When the cover lens becomes pitted or frosted, replace it.

3.0 FIELD INSTALLED ACCESSORIES

3.1 Alox Kit

3.1.1 The optional aluminum oxide kit is available factory installed or may be field installed later. Factory installed Alox kits consist of rubber curtains with eyelets, curtain hardware, and a boron carbide nozzle. Field installed kits also include a new section of light-lined flex hose. Refer to Section 3.2 for curtain installation.

3.2 Curtain Installation, Figure 8

3.2.1 Match the curtains to the corresponding wall and door as shown in Figure 8. Hook the curtains to the J-Hooks welded along the top of the front, back, and side walls. Cut openings for the hoses on the lower left rear wall.

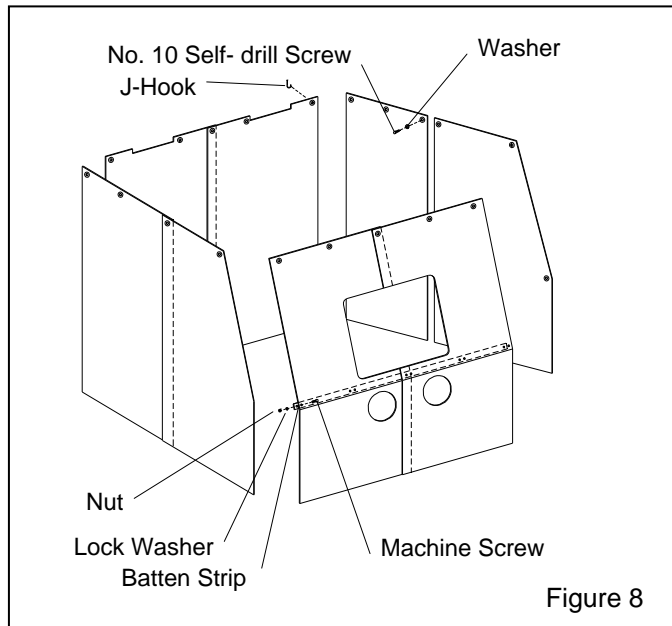

3.2.2 Using protectors against the curtains and outer doors, clamp the door curtains in place. The upper edges of the door curtains should be even with the outer edges of the sound proofing panel. Insert a #10 self-drilling screw with an 11/16" OD flat washer through the grommet holes. Use a screw gun with a 5/16" socket to attach the door curtains.

3.2.3 For front walls, place the batten strip over the curtain, and clamp it in position on the front slope above the break as shown in Figure 8. Match drill .187" (3/16") diameter holes through the rubber and cabinet front at each batten hole. To install the batten insert #10-24 x 1" round head machine screws through the cabinet front, curtain and batten. Install lock washers and nuts from inside the cabinet and tighten securely.

3.3 Manometer

The optional manometer kit is listed in Section 9.1.

3.3.1 Constant static pressure balance is necessary for precise media separation, as the reclaimers efficiency is accomplished by a centrifugal balance of air flow, particle weight, and size. The manometer measures static pressure. Static pressure is set by adjusting the outlet damper; refer to Section 5.3 to adjust static pressure. Refer to Section 5.7 for manometer instructions.

3.4 Track and Turntable Assembly

3.4.1 Description

3.4.1.1 These instructions cover field installation of the 2000 lb. capacity track and work cart with turntable. If the track was ordered with the cabinet, it is partially assembled at the factory. Disregard the instructions that do not apply. Refer to Figure 9 for arrangement of the major components.

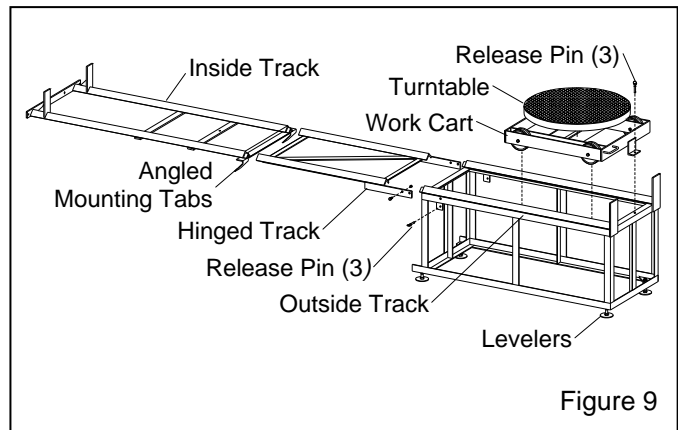

3.4.2 Install Inside Track, refer to Figure 10

3.4.2.1 Lay the inside track on the cabinet hoppers and above the grate as shown in Figure 10.

3.4.2.2 Push the end support bar against the inside cabinet wall, opposite the door, and insert the angled tabs on the door end of the track into the two sleeves on the hopper as shown.

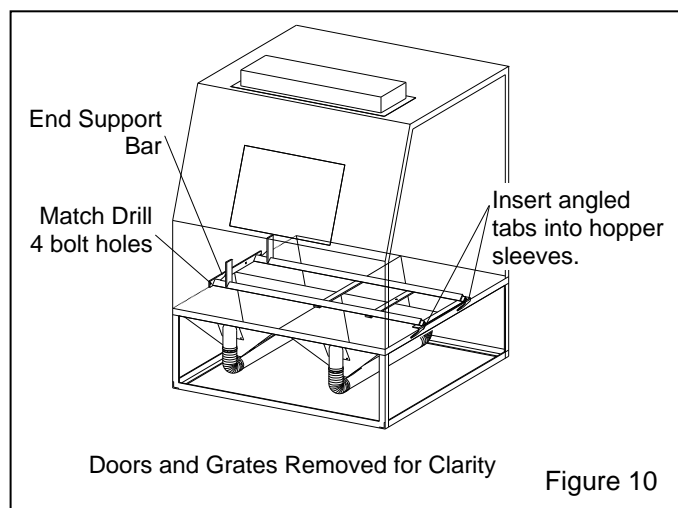

3.4.2.3 Make sure the weight of the track is evenly distributed over the hoppers and match drill for 3/8 fasteners through the cabinet wall, at the four hole locations in the end support bar. If necessary, mark the hole locations and remove the track for drilling.

3.4.2.4 Secure the inside track to the cabinet with four 3/8-NC cap screw, flat washers, lock washers, and nuts provided.

3.4.3 Position Outside Track, refer to Figure 11

3.4.3.1 Place the outside track so it is in-line with the inside track. Space the track so the top rails (not the smaller support rails) on the hinged end are approximately 42-inches from the top rails on the inside track.

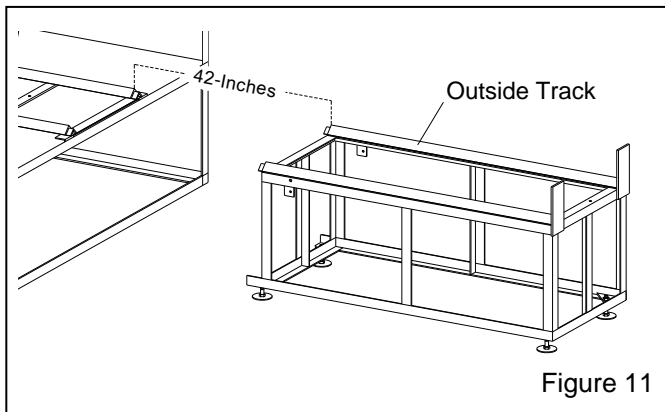

Figure 11

3.4.4 Attach Hinged Track, refer to Figure 12

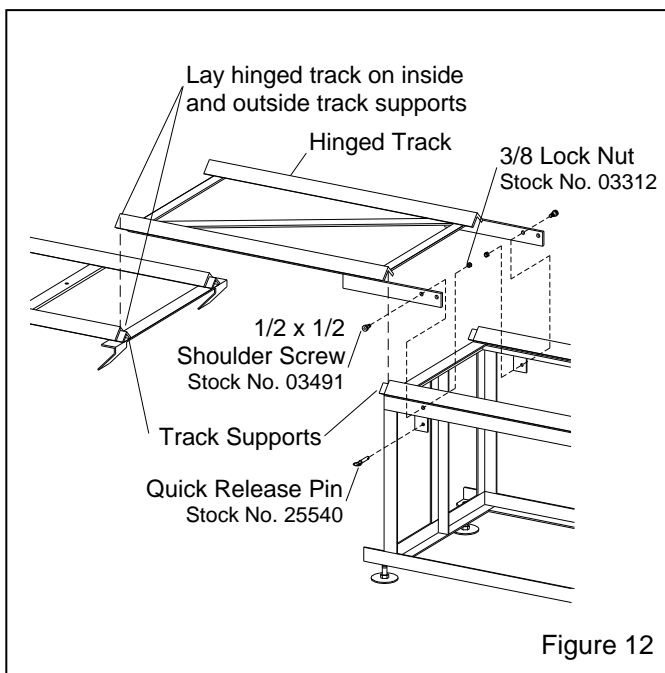

Figure 12

3.4.4.1 With the door open, place the hinged track on the inside and outside track supports, as shown in Figure 12. Maneuver the outside track as needed to align the hinge track bolt holes with the outside track bolt holes, while making sure hinge track is fully resting (with no gaps) on the track supports.

3.4.4.2 Install 1/2" shoulder screws through the both hinged track pivot-bars and into the holes in the outside track. Secure with 3/8 lock nuts.

3.4.4.3 Raise or lower the four adjustable foot pads on the outside track as needed to level it to the hinged track and inside track.

3.4.4.4 The quick release pin holds the hinge track when in the raised position, as shown in Figure 13.

3.4.5 Turntable Work Cart and Hinge Track Operations, refer to Figure 13

3.4.5.1 Set the work car on the outside track; the grooves in the wheels are designed to ride on the top of the track rails.

3.4.5.2 For shipping purposes, some field installed or replacement turntables may not be installed in the work cart. If shipped separately, slide the turntable shaft through the rubber bearing protector, bearing collar and bearing. When the turntable shaft is fully seated in the bearing, use a hex key to tighten the collar on the shaft.

3.4.5.3 Move the work cart toward the track stops until the hole in the pin bracket is aligned with the hole in the outside track cross brace. Insert the release pin through both holes to prevent the work cart from moving. Note: A similar hole is in one of the inside track cross braces. Inserting the pin through the work cart and inside track hole prevents the work cart from moving when inside the cabinet.

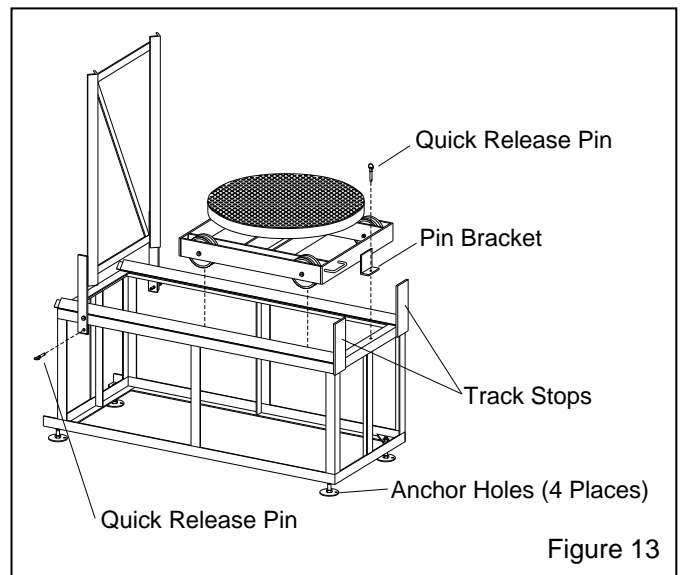

Figure 13

3.4.5.4 When certain the tracks are aligned, level, and the work car moves smoothly on all tracks, anchor the

outside track to the floor through the holes in the foot pads.

3.4.5.5 Raise the hinged track until the locking hole in the pivot-bars is aligned with the hole in the bracket on the bottom side of the outside hinge. Install a quick release pin on both sides of the track to hold it vertical.

WARNING

Always insert pins in both sides of the hinged track to lock it upright, when it is lifted vertical. The track could fall if left unlocked and cause severe injury.

4.0 OPERATION

4.1 Media Loading and Unloading

4.1.1 Media Capacity: Media capacity is 2 cubic feet. Full capacity is when media is at the pop-up valve opening. Overfilling will result in media carryover to the dust collector and possible blockage in the conveying hose.

4.1.2 Media Loading: With the exhauster off, add clean dry media, by pouring it into the reclaimer hopper through the reclaimer door. **Do not pour media directly into the cabinet hopper, as over filling may occur.** Overfilling will result in media carryover to the dust collector and possible blockage in the conveying hose. Refill only after all media has been recovered from the cabinet.

4.1.3 Media Unloading: To empty the cabinet and blast machine of media, allow all media to be recovered from the cabinet, and reduce pressure to 40 psi. Place an empty container, such as a bucket, on the cabinet grate. Remove nozzle and nozzle washer, close the door, close the choke valve and press the foot pedal. Direct media flow into the container. Empty the container when full or before it is too heavy to handle, and repeat the process until the machine is empty. Return the choke valve to the full open position. Clean the nozzle holder threads and inspect the threads on the nozzle and nozzle holder before reinstalling the nozzle washer and nozzle. If complete purging of media is required, use a vacuum to clean media residue in cabinet hopper and blast machine head.

4.2 Loading and Unloading Parts

WARNING

Use solid fixturing to hold heavy parts in place. Do not remove lift equipment until the part is adequately supported to prevent movement. Moving heavy, unsupported parts may cause them to shift or topple, resulting in severe injury. This is especially important with the use of turntables and turntables with tracks.

4.2.1 Load and unload through the door.

4.2.2 Parts must be free of oil, water, grease, or other contaminants that will clump media or clog filters.

4.2.3 When blasting very small parts, place an appropriately sized screen over the grate to prevent parts from falling into the hopper. If an object should fall through the grate, stop blasting immediately and retrieve it.

4.2.4 Close door; the door interlock system will prevent blasting if door is open.

4.3 Blasting Operation

CAUTION

- **Always close cabinet, reclaimer and dust collector doors before blasting. Keep all doors closed during blasting.**
 - **Always wear blast gloves.**
 - **Avoid pointing the blast nozzle toward the view window.**
 - **Use the blow-off nozzle to blow media off parts before opening doors.**
 - **After blasting, keep doors closed and exhauster on until the cabinet is clear of all airborne dust.**
 - **Stop blasting immediately if dust leaks are detected.**
-

4.3.1 Slowly open the air valve on the air supply hose to the blast machine. Check for air leaks on the initial start up and periodically thereafter.

4.3.2 Turn on the lights and exhauster. The push-button switch located on the face of the control panel performs both functions. Pull the button to start the exhauster.

4.3.3 Load parts.

4.3.4 Close door; the door interlock system will prevent blasting if the door is open.

4.3.5 Insert hands into gloves.

4.3.6 Firmly grasp the nozzle and step on the foot pedal. Blasting will begin almost immediately.

WARNING

Shut down the cabinet immediately if dust leaks from the collector. Make sure filters are correctly seated and not worn or damaged. Prolonged breathing of any dust could result in serious lung disease or death. Short term ingestion of toxic dust such as lead, poses an immediate danger to health. Toxicity and health risk vary with dust generated by blasting. Identify all material being removed by blasting, and obtain a material safety data sheet for the media.

NOTE: When blasting small parts, use a solid back rest for the part. Without this assist, especially with longer blasting operations, the operator will tire from resisting blast pressure. Whenever possible avoid holding small parts that require blasting into the glove. If the part does not maintain contact with the grate, which dissipates static through the metal cabinet, a static charge could build-up in the part and cause shocks.

4.3.7 Adjust the pilot pressure regulator located on the left side of the cabinet, to the required blasting pressure, per Section 5.1.

4.4 Stop Blasting

4.4.1 To stop blasting, remove pressure on the foot pedal. The blast machine will depressurize each time the foot pedal is released.

4.4.2 The blast machine refills with media stored in the reclaimer each time the foot pedal is released. Refilling takes approximately 15 seconds.

4.4.3 Use the blow-off nozzle to blow media off cleaned parts. Allow the exhauster to clear the cabinet of airborne dust before opening the door.

4.4.4 Unload parts, shut off the air supply valve, and switch off the lights and exhauster.

4.5 Blasting Technique

4.5.1 Blasting technique is similar to spray painting technique. Smooth continuous strokes are most

effective. The distance from the part affects size of blast pattern. Under normal conditions, hold the nozzle approximately 6" from the surface of the part.

5.0 ADJUSTMENTS

5.1 Blasting Pressure

5.1.1 The pilot pressure regulator, located on the left side of the cabinet, enables the user to adjust the blasting pressure to suit the application. The suitable pressure for most purposes is around 80 psi. Lower pressures may be required on delicate substrates, and will reduce media breakdown. Higher pressure may be required for difficult blasting jobs on durable substrates, but will increase media break down. In all cases, highest production can only be achieved when pressure is carefully monitored.

5.1.2 If the application requires blasting below 40 psi, first pressurize the blast machine at 40 psi, and then turn the pressure to the required setting before blasting the part. If the initial pressure is below 40 psi, the pop-up valve may not seal.

5.1.3 Pressure registers on the gauge only while blasting. While holding the nozzle securely, adjust air pressure at the pilot regulator, located on the left side of the cabinet.

5.1.4 To adjust, pull out on the knob out to unlock it, turn it clockwise to increase pressure or counter-clockwise to decrease pressure. Once operating pressure is set, push in on the knob to lock it and maintain the setting.

5.2 Media Metering

These instructions are for a standard cabinet with Sentinel Metering Valve. Optional metering valves may function differently, but the process is similar.

5.2.1 Media flow is adjusted by the metering valve located at the bottom of the blast machine. The valve is closed when the handle is fully to the right. To adjust, close the valve and slowly move the handle to the left to increase media flow. Allow time for the flow to stabilize before further adjusting. The valve is fully open when the handle is at the full left position. The correct flow rate depends on the type and size of media and blasting pressure, and can best be determined by experience. Use as little media as possible while maintaining the best cleaning rate. Generally, with the correct mixture, abrasive can be seen as light discoloration as it exits the nozzle.

5.3 Reclaimer Static Pressure (outlet damper)

5.3.1 Constant static pressure balance is necessary for precise media separation. Correct static pressure varies with the size of reclaimer and the size, weight and type of media.

5.3.2 Adjust static pressure by opening (handle inline with air flow) or closing (handle perpendicular to air flow) the damper. The damper is located on the dust collector inlet on dry filters, and on the outlet of reverse pulse collectors. If the damper is not opened enough, the reclaimer will not remove fines, resulting in dusty media, poor visibility, and possible media blockage in the conveying hose. If the damper is opened too far, it may cause carryover (usable media carried into the dust collector) and result in excessive media consumption. Open only as far as necessary to obtain a balance of dust removal without media carryover.

5.3.3 A manometer is useful when adjusting or monitoring static pressure. The optional manometer kit is listed under Optional Accessories in Section 9.1. Refer to Section 5.7 for operation. The following are static pressure starting points for given media. Static pressure may need to be lower with finer media and higher with coarser media. Run the media through several blast cycles allowing the reclaimer to function with these settings. Inspect the media in the reclaimer and fines in the dust collector as noted in Paragraph 5.3.2. Continue adjusting static pressure until optimum media cleaning without carryover is attained.

Glass Bead No. 8 to 13	2-1/2 - 3"
Alox. 60 & coarser	4 - 5"
Alox. 80 & finer	2-1/2 - 3"
Steel Grit	6 - 7"

5.3.4 If the damper has been adjusted and carryover or excessive dust in the media continues, the optional adjustable vortex cylinder, which is standard on pull through reclaimers, may help by fine-tuning media separation. The vortex cylinder is usually required only when using 180 mesh and finer media, or lightweight media. Refer to Section 5.4, and Accessories in Section 9.1.

5.4 Optional Externally Adjustable Vortex Cylinder (standard on pull-through reclaimers).

5.4.1 The vortex cylinder fine-tunes media separation. Before adjusting the vortex cylinder, adjust the damper on the dust collector to increase or decrease static pressure per Section 5.3. After adjusting the damper, adjust the cylinder as follows. Adjustments are made by loosening the handle's locking knob and moving the handle to achieve the correct setting. When the correct

setting is established, tighten the locking knob to prevent movement. Start with the lever slightly to the right (about one o'clock) of the vertical position.

5.4.2 To Remove More Fines: (Too much dust in media) Raise the cylinder by moving the lever left toward "COARSE", in 1/4" increments at the indicator plate. It may take a few cycles to remove the fines; allow the media to go through several cycles before determining if further adjustment is required.

5.4.3 To Remove Less Fines: (Too much usable media is carried to the dust collector) Lower the vortex cylinder by moving the lever right toward "FINE", in 1/4" increments at the indicator plate. Run the media through a cycle and check the dust container to determine if further adjustment is required. Note: If the cylinder is lowered too far, the reclaimer will again begin to allow usable media to be carried over, and cause abnormally high static pressure.

5.4.4 When using very fine media (180 mesh and finer), the inlet baffle of the reclaimer may also need to be removed. Consult the factory before proceeding with this option.

5.5 Door Interlocks, Figure 14

WARNING

Never attempt to override the interlock system. Doing so could result in injury from unexpected blasting.

5.5.1 The door interlocks disable the blasting control circuit when either door is open. To enable blasting, the door interlock switch must be engaged when the doors are closed. The interlocks are set at the factory and do not usually require field adjustment unless parts are replaced. When adjustment is required, proceed as follows.

5.5.2 Close cabinet doors.

5.5.3 Loosen the actuator bracket screws and adjusting screw nut. Move the actuator adjusting bracket up or down, and the adjusting screw sideways, to center the adjusting screw on the over-travel stop. Tighten the bracket screws.

5.5.4 Turn the adjusting screw in or out as required to engage the switch without applying excessive pressure on it. Tighten the adjusting screw nuts.

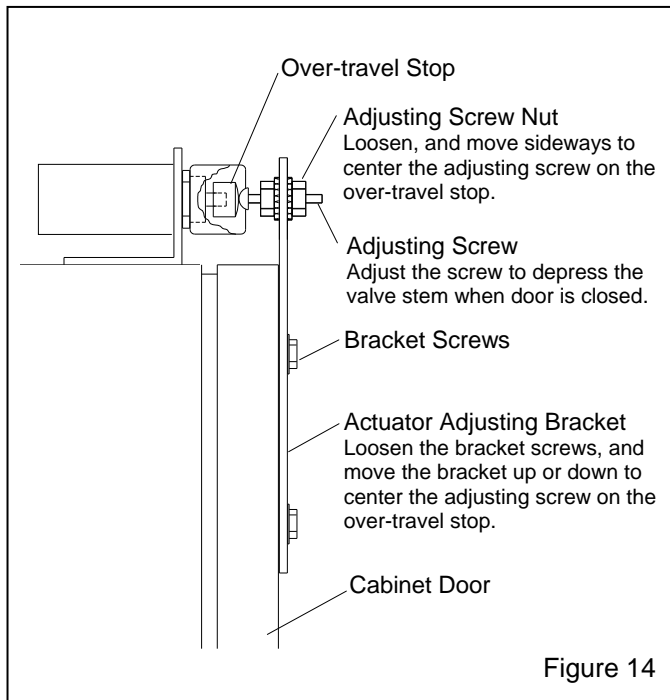

5.5.5 Test the operation with the doors open and then again closed. Point the nozzle away from the door during the tests, and only open the door enough to disengage the interlock switch. The interlocks should stop the blasting when the doors are opened, and permit blasting when the doors are closed. NOTE: Negative pressure inside the cabinet may cause the doors to flex inward. Tests should be performed with the exhauster running.

5.6 Intake Stack with Damper (cabinet static pressure)

5.6.1 Once the inlet is initially set per Section 2.14, it seldom requires readjustment. The initial setting produces approximately .5" to .75" of static pressure in the cabinet enclosure. **Do not confuse cabinet static pressure with reclaimer static pressure as noted in Section 5.3, which is controlled by the outlet damper. Reclaimer pressure must be set before cabinet pressure.** In rare circumstances, cabinet pressure may need to be slightly higher or lower.

5.6.2 A manometer (listed in Section 9.1) is the most accurate method of monitoring and adjusting cabinet pressure. Following the instructions packed with the manometer, start the exhauster and insert the needle into a glove, and adjust pressure using the inlet damper. Open the damper further to decrease static pressure or close it further to increase pressure.

5.6.3 If a manometer is not available, use the gloves as an indicator. With the exhauster running, the gloves should be inflated, but not elevated off the grate.

5.7 Optional Manometer

NOTE: These instructions show several methods of taking static pressure readings (negative pressure) on cabinet reclaimers, using a flexible tube manometer. Use the method best suited for the application. The instruction explains the processes for taking periodic readings and shows how to permanently install the manometer for taking frequent readings. Permanent fittings should be installed when rigid ducting is used, or when the manometer installation is permanent. Use silicone sealer or other sealant to seal around the fitting to prevent leaks. The fitting should be capable of being capped when the manometer tube is removed. This will prevent leaks that alter the reclaimer's separation efficiency. Taking readings at different locations could produce different readings. Static pressure readings at the door are generally .5" to 1" lower than those taken above the reclaimer. The readings are reference points, so readings should be taken using the same method each time the reading is taken.

5.7.1 Refer to directions packed with the manometer for preparation and operating instructions for the manometer.

5.7.2 Connect one end of the 3/16" ID tubing to one of the tubing connectors (elbow) at the top of the manometer, by pushing it over the barbed adaptor.

5.7.3 Leave the needle protector on the needle and insert the needle into the other end of the tubing. The ends of the tubing must fit tight on the manometer and needle; leaks will give inaccurate readings.

5.7.4 Open both manometer valves (elbows) per the instructions with the manometer.

5.7.5 Magnets on the manometer hold it in position on the reclaimer body. The manometer must be vertically-plumb so the fluid is level on both sides.

5.7.6 Needle placement: Ref. Figure 15.

5.7.6.1 Pull-thru systems (reclaimer without exhauster): Remove the needle protector, and insert the needle into the flex hose approximately 8" from the top of the reclaimer. The method shown for push-thru systems may also be used.

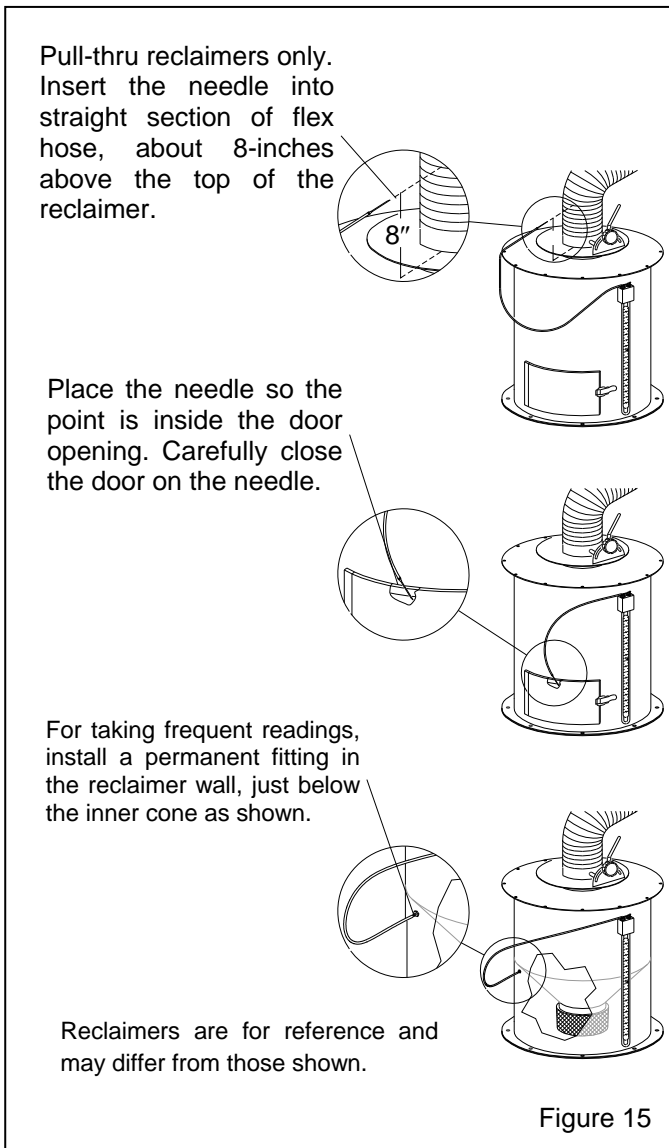

5.7.6.2 Push-thru systems (reclaimer with exhauster): Open the reclaimer fill door, remove the needle protector and place the needle so the point is inside the door opening. Carefully close the door on the needle. The side of the needle will embed into the rubber, creating an airtight seal.

5.7.7 Turn the exhauster ON. The negative (static) pressure will move fluid in the tube.

NOTE: Readings must be taken with the cabinet doors open, and with the exhauster running.

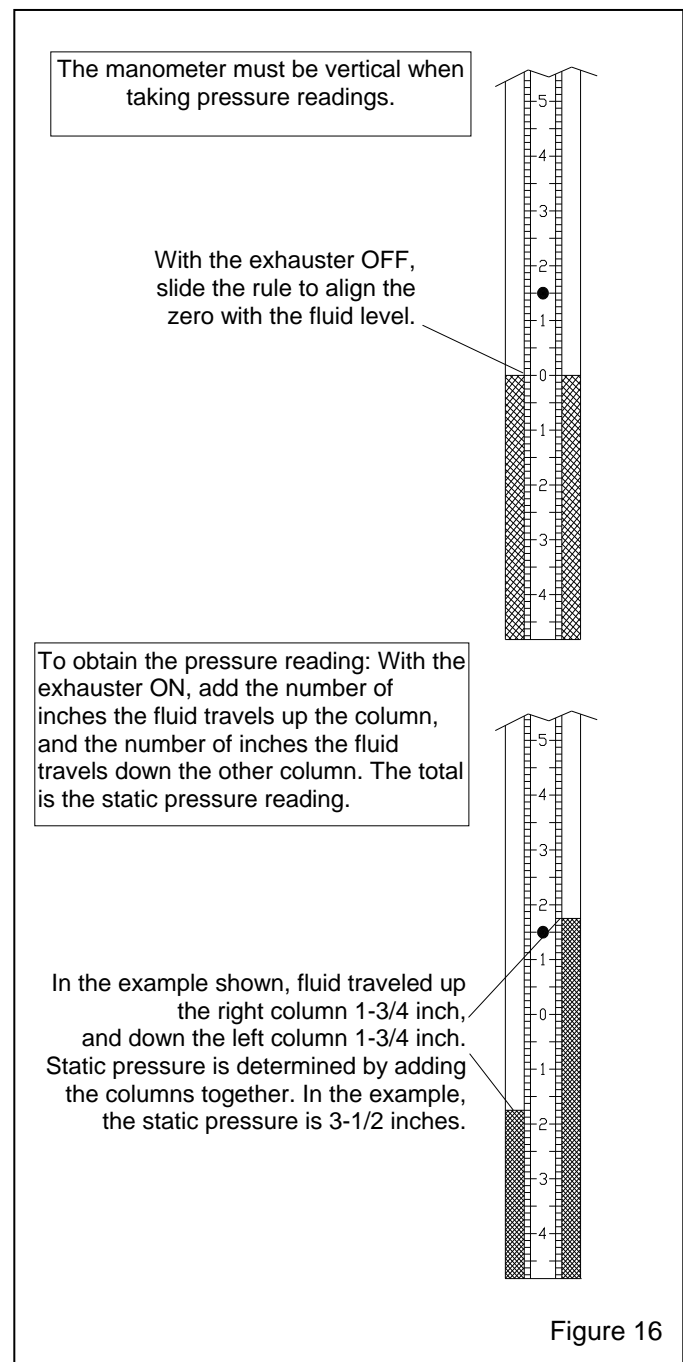

5.7.8 To find the static pressure, add the number of inches the fluid travels up one column to the inches the fluid travels down the other column. Refer to the example in Figure 16.

5.7.9 After the readings are taken, replace the needle protector. Close the manometer valves and store the manometer in the original container in a clean area. Note: If the manometer installation is permanent, the manometer may remain on the reclaimer body after the valves are closed.

6.0 PREVENTIVE MAINTENANCE

WARNING

Failure to wear approved respirators and eye protection when servicing dust-laden areas of the cabinet and dust collector, and when emptying the dust collector could result in serious eye irritation and lung disease or death. Toxicity and health risk vary with type of media and dust generated by blasting. The respirator must be approved for the type of dust generated. Identify all material being removed by blasting, and obtain a material safety data sheet for the blast media.

NOTE: To avoid unscheduled downtime, establish a weekly inspection schedule. Inspect all parts subjected to media contact, including; nozzle, blast hose, flex hose, plus all items covered in this section.

6.1 Dry Filter Dust Collector

Refer to the Reverse Pulse Dust Collector Manual for Maintenance of the Dust Collector

6.1.1 The dry filter uses tubular filters which collect dust on their inner surfaces. A shaker arm extending to the outside of the collector is used to shake the filters. At least every two hours, turn off the exhauster and shake the filters vigorously.

NOTICE

Do not shake the filters when the exhauster is running. Doing so will accelerate wear on the filters around the shaker assembly, but not loosen dust from the filters.

6.1.2 Empty the dust collector drawer regularly. Begin by checking the drawer daily and adjust frequency based on usage and break down rate of media. Dump the contents into a suitable disposal container.

CAUTION

Do not open the dust drawer door while the exhauster is running. The drawer chamber is under positive pressure when the exhauster is on. Opening the dust door while the exhauster is running or the paddle wheel rotating will allow dust to escape.

NOTE: Blast media is not usually toxic, however, some materials removed by the process may be. Check with proper authorities for disposal restrictions.

6.2 View Window Cover Lens

6.2.1 Rapid frosting of the view window can be avoided by directing ricocheting media away from the window, and by installing a cover lens on the inside surface of the window. Using cover lenses prolongs the life of the view window.

6.2.2 The best way to install a cover lens is to remove the window from the cabinet. If, for any reason, it is not practical to remove the window, the lens may be applied with it in place.

6.2.3 To install a cover lens, carefully remove the adhesive backing making sure the adhesive remains on the lens, and apply the lens to the clean, dry, inner surface of the view window. When the cover lens becomes pitted or frosted, replace it.

6.3 Reclaimer Debris Screen

6.3.1 The screen is accessible through the reclaimer door. With the exhauster off, remove the screen and empty it daily or when loading media. Empty the screen more often if parts being blasted cause excessive debris. Do not operate the machine without the screen in place.

6.4 Air Filter

6.4.1 The cabinet is equipped with an auto-drain air filter. The filter automatically drains when moisture fills the bowl to a certain level. Moist air inhibits the flow of media. If the filter does not remove enough moisture to keep media dry and flowing, a dryer or after cooler may be required in the air supply line.

6.5 Abrasive Trap (optional)

Recommended for 40 mesh and coarser media.

6.5.1 Check and clean the abrasive trap screen and empty the trap twice a day.

6.6 Diaphragm Outlet Valve

6.6.1 Remove the cap four screws and inspect the diaphragm. Replace the diaphragm if worn or cracked or otherwise damaged. Continued use with a worn diaphragm will quickly wear the valve casting.

6.7 Blast Hose

6.7.1 To avoid unscheduled down-time, inspect the blast hose for thin spots by pinching it every 12 to 18 inches. The first sign of wear is usually along the outside radius. Check coupling gaskets and couplings for leaks and wear.

7.0 SERVICE MAINTENANCE

WARNING

Failure to wear approved respirators and eye protection when servicing dust-laden areas of the cabinet and dust collector and when emptying the dust collector could result in serious eye irritation and lung disease or death. Toxicity and health risk vary with type of media and dust generated by blasting. Identify all material being removed by blasting, and obtain a material safety data sheet for the blast media.

7.1 Gloves

7.1.1 Special static-dissipating gloves have been provided for operator comfort. It will be necessary to change gloves periodically as they wear. The first sign of deterioration may be excessive static shocks.

7.1.2 Gloves are held in place by metal bands on the inside of the cabinet. To replace, loosen the bands with a screwdriver, replace the gloves, and tighten the bands.

7.2 Nozzle

7.2.1 Replace the nozzle when its diameter has increased by 1/16", or sooner if pressure diminishes noticeably. Make sure the nozzle gasket is in good condition and in place before screwing the nozzle into the nozzle holder.

7.3 View Window Replacement

WARNING

Do not use plate glass for replacement view windows. Plate glass shatters on impact and could cause severe injury. Use only genuine replacement parts.

7.3.1 Remove the two window frame nuts located on the upper edge of the window frame, and swing the window frame open. NOTE: If the frame is to remain open, for cleaning or other reasons, remove it per Section 7.5.

7.3.2 Remove the old window.

7.3.3 Inspect the window frame gaskets, on both the window frame and on the cabinet. If either gasket is damaged, replace it per section 7.4.

7.3.4 Install view window cover lens per Section 6.2.

7.3.5 Set the new window (cover lens down) squarely over the window opening, ensuring that all edges of the window are centered and overlapping the window gasket, and that the window is resting on the lower support tabs.

7.3.6 Swing the window frame into place and tighten the frame nuts.

7.4 Window Gasket Replacement, Figure 17

7.4.1 Inspect the gaskets when changing the view window. Replace the window frame gasket and cabinet window opening gasket at the first sign of media leakage around the view window, or if gaskets are worn or otherwise damaged.

7.4.2 Remove the window and window frame per Section 7.5.

7.4.3 Remove all the old gasket material and clean the surfaces of the cabinet and window frame.

7.4.4 Peel a short section of adhesive backing from the 5/16" thick strip gasket, and adhere the gasket to the center of the top edge of the window opening as shown in Figure 17. Peel additional backing as needed, and work the strip around the radius of each corner, pressing it tightly to bond. Trim the gasket to fit and compress the ends to seal.

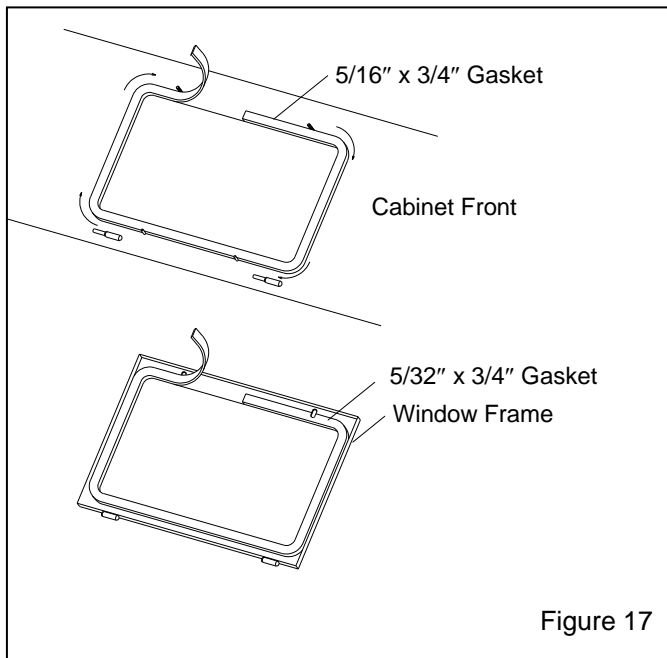

Figure 17

7.4.5 Using 5/32" thick strip gasket, repeat the process on the window frame.

7.4.6 Trim around the window frame bolts slots, as needed.

7.5 Window Frame Removal, Figure 18

7.5.1 Remove the two window frame nuts located on the upper edge of the window frame, and swing the window frame open.

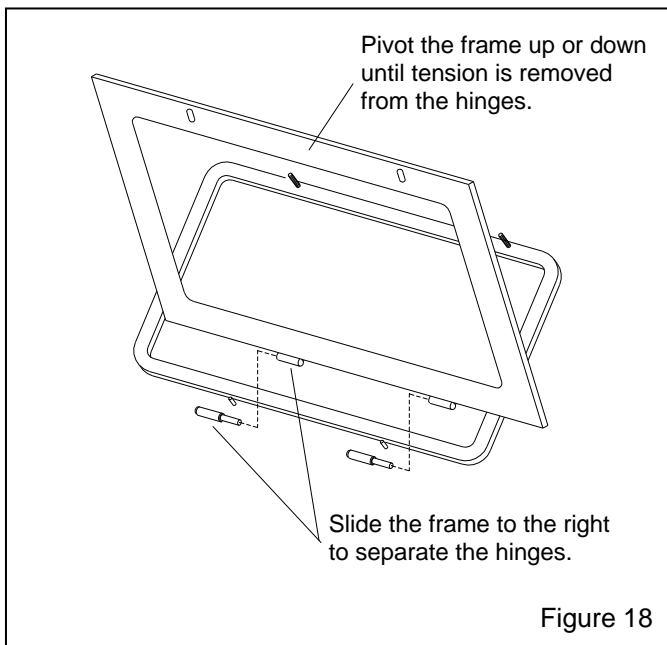

Figure 18

7.5.2 Remove the window to prevent breakage.

7.5.3 Pivot the window frame up or down until tension is off the frame hinges.

7.5.4 To remove, slide the frame to the right. The hinges separate as shown in Figure 18.

7.5.5 Replace the frame in reverse order. Align the top bolt holes with the bolts; slide the frame as necessary.

7.5.6 Set the window squarely over the window opening, ensuring that all edges of the window are centered and overlapping the window gasket, and resting on the lower support tabs.

7.5.7 Swing the window frame into place and tighten the frame nuts.

7.6 Dry Filter Tube Replacement

CAUTION

- Do not bend spring ends so tightly that the springs kink.
- Do not use a sharp instrument to force spring rings into the opening. This could damage the filter and seriously impair the function of the dust collector.
- Install one filter at a time. Check the seating of the top and bottom spring rings, and make sure the tube is not twisted, before proceeding to the next.

7.6.1 Replace damaged filters immediately. Remove the old filters by pulling the spring rings off the bottom and top tube plates. Working from the back to the front, install one filter at a time. To install new filters, form the end of the spring ringed tubular filter into a shallow "c" shape. Push the filter far enough into the hole of the top plate to allow one spring ring to snap into place above the tube plate and the other to snap into place below it. See the illustration in Figure 19.

7.6.2 The tubular filter is held firmly by a spring ring above and below the perimeter of the hole in the plate. The other end of the filter is similarly installed in the lower plate. The filters fit tightly to prevent dust leakage. To ensure a tight seal, some force may be required by the installer. Check for proper seating at both ends, and remove any twist in the tube before proceeding to the next filter.

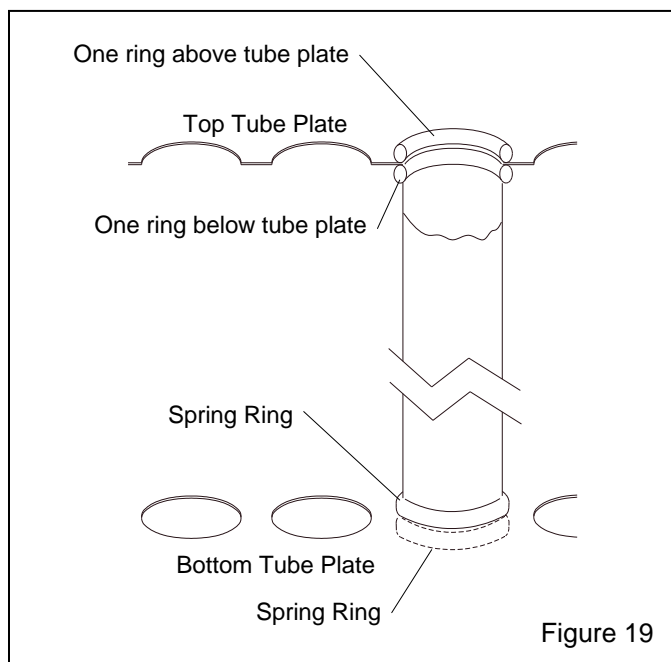

guide will make it difficult to remove the next time the pop-up valve needs replacement.

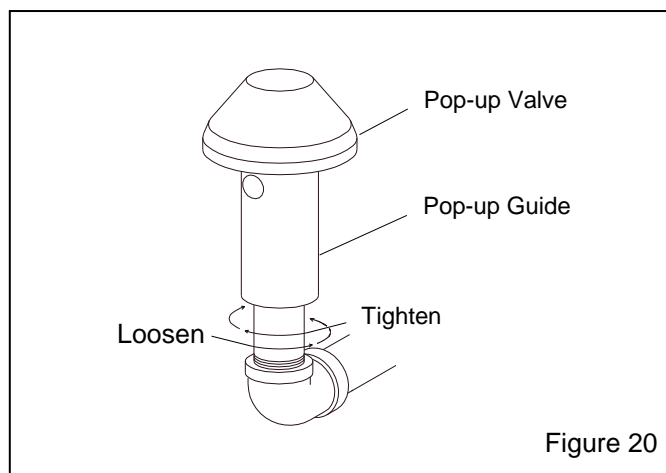

7.7.6 Put a new gasket on the inspection door and bolt the door onto the machine.

7.7 Pop-up Valve Replacement

7.7.1 Empty the machine of media as described in Section 4.1.3.

7.7.2 Depressurize the blast machine, and lockout and tagout the compressed air supply.

⚠ WARNING

Failure to observe the following procedure before performing any maintenance could cause serious injury or death from the sudden release of compressed air.

- **Depressurize the media chamber**
- **Lockout and tagout the compressed air supply.**
- **Bleed the air supply line to the media chamber.**

7.7.3 To gain access to the pop-up valve, remove the inspection door assembly.

7.7.4 Using a small pipe wrench, unscrew the pop-up valve guide as shown in Figure 20, by turning it counterclockwise. Remove the pop-up valve and guide from the machine.

7.7.5 Slide the new pop-up valve over the guide, and then screw the valve guide (with the pop-up valve on it) into position inside the machine. Tighten the guide wrench-snug, but not wrench-tight. Over-tightening the

7.8 Pop-up Valve Seat Replacement

7.8.1 The easiest method to replace the rubber pop-up seat is through the reclaimer access door. If for any reason replacement cannot be made through the reclaimer, observe the warning in Section 7.7, and empty the machine and bleed the air supply line. Remove the inspection door assembly and work through the opening.

7.8.2 Remove the old seat by using a finger, screwdriver, or similar object, to work the seat out of the retainer groove.

7.8.3 Push the new seat all the way through the port and then fit it into the groove. For the last few inches, pull up on the seat and allow it to "pop" into position.

7.9 Reclaimer Wear-Plate Replacement

7.9.1 Remove the reclaimer inlet adaptor and old wear plate. The wear plate is held in place with screws installed from the outside of the reclaimer; remove the screws and pull out the wear plate from the reclaimer inlet.

7.9.2 Angle the new wear plate into reclaimer inlet until it is in position with the straight end at the reclaimer inlet. Using a board or similar object for leverage, pry the wear plate against the inner wall of the reclaimer. Install sheet metal screws through the old screw holes to secure. Caulk any gaps or voids around the wear plate to prevent rapid wear in those areas.

7.10 Replacing or Field Installing Optional Rubber Reclaimer Liners, Figure 21. The reclaimer must be designed for liners and have a removable top. If the reclaimer is currently unlined, begin at the installation note preceding Paragraph 7.11.9.

7.10.1 Remove the inlet and outlet flex hoses.

7.10.2 Remove the screw that secures the inlet-top liner to the reclaimer top.

7.10.3 Remove the bolts securing the reclaimer top, and then remove the top, top liner and tube (inner cylinder) liner.

7.10.4 Remove the bolts located along the side of the inlet, and remove the Inlet-baffle.

7.10.5 To remove the inlet-top liner, remove the self-drilling screws securing it to the top of the inlet.

7.10.6 Wall liner and inlet-side liner are held in place with self-drilling screws. From the outside of the reclaimer, remove the screws, and remove the liners.

7.10.7 Inner cone liners and cone-ring liners are glued onto the inner cone. Pull the liners to remove them.

7.10.8 Remove remnants of old caulking and adhesive from the weldment.

Installation Note: The numbers in parentheses () shown in Figure 21 and the applicable paragraphs, show the recommend order of installation. When installing the liners, make sure that seams are aligned. The final assembly must be smooth and free of protrusions, edges, and gaps. Any edges will disrupt the air flow, causing wear, and affect the reclaimer's media cleaning efficiency.

7.10.9 (1st) Place the cone-ring liner on the inside of the cone-ring; check fit and trim if needed. Apply medium-set contact cement to the fabric side and install the liner. Note: Follow the instructions provided with the adhesive, some adhesives require covering both surfaces to be cemented. Smooth out the liner to eliminate air pockets.

7.10.10 (2nd) Place the cone liner in the cone with the fabric side down, and check the fit, trim if necessary. Follow the instructions provided with the adhesive and apply medium-set contact cement to the fabric side, and install the cone liner. Smooth out the liner to eliminate air pockets.

7.10.11 (3rd) Position the inlet-side liner and inlet-top liner to make sure they fit. Trimming is occasionally required. Align the inlet-side liner and inlet-top liner and

clamp them in place. Use self-drilling screw at each hole location in the weldment to secure the liners.

7.10.12 (4th) Clamp the wall liner in place, making sure it is flush with the top of the reclaimer body and aligned with the inlet. Mark the wall liner at the three bolt-hole locations for the inlet baffle. Remove the liner and drill the bolt holes. Reinstall the wall liner. Align the three bolt holes and temporarily place bolts through the holes to hold it in place. Clamp the liner, and while pushing the liner against the weldment, secure it with self-drilling screws, through each screw hole in the weldment. Remove the temporary inlet-baffle bolts after the liner is secured.

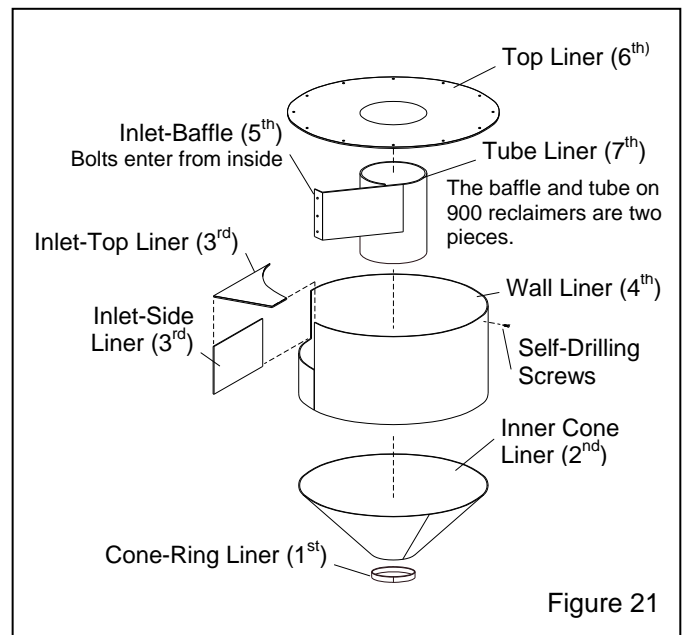

Figure 21

7.10.13 Use silicone caulking to seal seams around the inlet-side liner and reclaimer weldment, and between the inlet-top liner and wall liner seam. Apply caulking at the seams of the cone-ring liner and cone liner and between the cone liner and wall liner. Wipe the caulking smooth.

CAUTION

All seams between each liner must be sealed, and all seams between the liners and reclaimer weldment must be sealed. Voids will cause premature wear.

7.10.14 (5th) Install the inlet baffle; bolts should be installed from the inside of the reclaimer to attach nuts from the outside.

7.10.15 (6th) Slide the top liner over the inner tube and align the holes in the liner with those in the top. Note that the holes around the inlet are spaced differently

from the others. Temporarily install a couple of bolts to keep the alignment.

7.10.16 (7th) Place the tube liner over the inner tube, and use worm clamps to temporarily clamp the liner to the tube. Align it so the seam is on the backside (away from the inlet). Make sure the liner is tight against the top liner, then tack the liner to the bottom of the inner tube in three or four places. Remove the clamps when the tube liner is secured.

7.10.17 Apply caulking to the seam on the tube liner, and between the tube liner and top liner.

7.10.18 Apply caulking around the top edge of the wall liner and inlet-top liner.

7.10.19 Align the reclaimer top assembly and lower it into place being careful not to smear the caulking. Secure the top bolts and inlet baffle bolts.

7.10.20 Working through the reclaimer inlet, wipe the caulking seal smooth. Apply additional caulking to the seam between the baffle and wall liner. Re-caulk any voids.

7.10.21 Install flex hoses.

7.10.22 Allow time for the caulking to cure before putting the reclaimer in service.

7.11 Sentinel Metering Valve

Refer to the Sentinel media metering valve manual for service.

7.12 Reverse-Pulse Dust Collector

Optional reverse-pulse dust collectors are covered in a separate manual.

8.0 TROUBLESHOOTING

WARNING

To avoid serious injury, observe the following when troubleshooting.

- **Turn off the air, and lockout and tagout the air supply.**
- **When checking the controls requires air, always enlist the aid of another person to: Hold the nozzle securely. Operate the foot pedal.**
- **Never bypass the foot pedal or wedge it in the operating position.**
- **Never override the door interlock system.**

8.1 Poor visibility

8.1.1 Dirty tube filters or filter cartridge. Shake tube filters, and empty dust drawer regularly. Refer to the RP dust collector manual for pulse pressure and sequence.

8.1.2 Exhauster motor not operating. Check voltage to motor and motor wiring.

8.1.3 Motor rotating backwards. The motor should rotate as indicated by the arrow on the housing. If it does not rotate in the proper direction, **Lockout and Tagout power** and switch the motor leads as shown on the motor plate. See Section 2.11.

8.1.4 Using friable media that rapidly breaks down, or using media that is too fine or worn out.

8.1.5 Outlet damper closed too far restricting air movement in cabinet. Adjust per Section 5.3.

8.1.6 Inlet damper requires opening. Restriction at the intake stack damper reduces air movement in the cabinet. Open damper per Section 2.14 and 5.6.

8.1.7 Hole worn in flex hose between cabinet hopper and reclaimer inlet. When using a reverse pulse dust collector also check the flex hose between the reclaimer outlet and dust collector inlet). Replace hose and route it with as few bends as possible to prevent wear.

8.1.8 Reclaimer door open.

8.1.9 Obstruction in flex hose between the cabinet hopper and reclaimer inlet.

8.1.10 Paddle wheel worn. Check wheel for wear.

8.2 Abnormally high media consumption

8.2.1 Door on reclaimer open, improper fit, or worn door gasket. Air entering the reclaimer around the door will cause media to be carried into the dust collector. DO NOT operate unless all doors are closed.

8.2.2 Dust collector damper open too far. Adjust static pressure per Section 5.3.

8.2.3 Media may be too fine or worn-out.

8.2.4 Using friable media that rapidly breaks down.

8.2.5 Nozzle pressure too high for the media, causing media to break down.

8.2.6 Hole worn in reclaimer, or leak in reclaimer seams. Check entire reclaimer for negative-pressure leaks.

8.2.7 Optional externally adjustable vortex cylinder requires adjustment. Adjust per Section 5.4.

8.2.8 If using very fine media (180 mesh and finer), the inlet baffle of the reclaimer may need to be removed. Contact Clemco Customer Service before proceeding with removal of the baffle.

8.2.9 Outlet valve not sealing. Inspect diaphragm.

8.3 Reduction in blast cleaning rate

8.3.1 Low media level. Check and refill if low.

8.3.2 Metering valve requires adjustment. Adjust per Section 5.2.

8.3.3 Reduced air pressure. This may be caused by a malfunctioning regulator, a dirty filter element in air filter, partially closed air valve, leaking air line, or other air tools in use.

8.3.4 Blockage in nozzle. Blockage may occur as a result of a missing debris screen.

8.3.5 Moist media. Frequent bridges or blockage in the area of the metering valve can be caused by moisture. See Section 8.5.

8.3.6 Outlet valve not sealing. Inspect diaphragm.

8.4 Plugged nozzle

8.4.1 A damaged or missing reclaimer screen will allow large particles to pass and block the nozzle. Inspect screen and replace or re-install as necessary.

8.5 Media bridging

8.5.1 Frequent bridging or blockage in the media metering valve can be caused by damp media. Media becomes damp by blasting parts that are slightly oily, from moisture in the compressed air line, or from absorption.

8.5.2 To avoid contaminating media from the workpiece, all parts put into the cabinet should be clean and dry. If parts are oily or greasy, degrease and dry them prior to blasting.

8.5.3 Moist compressed air may be due to a faulty compressor that overheats, or pumps oil or moisture into the air line, too long an air line permitting moisture to condense on the inside, and from high humidity. Drain filters and receiver tank regularly. If the problem persists, it may be necessary to change media more often, or install an aftercooler or air dryer.

8.5.4 Absorption. Some media tends to absorb moisture from the air, especially fine-mesh media in high humidity areas. Empty the media and store it in an airtight container when cabinet is not in use.

8.5.5 A vibrator mounted either on the blast machine leg or on a bolt on the media metering valve may help prevent bridging of fine-mesh media.

8.6 Neither media nor air comes out the nozzle when foot pedal is pressed

8.6.1 Depressurize the blast machine, and check the nozzle to see if it is plugged. See Section 8.4.

8.6.2 Make sure the blast machine pressurizes when the foot pedal is pressed. If it does not pressurize, refer to Section 8.11.

8.6.3 Make sure the media metering valve and the choke valve are open.

8.7 Blast machine will not depressurize or depressurizes too slowly

8.7.1 Check for blockage in the 4-way valve mufflers.

8.7.2 Check to see if the 3-way valve in the foot pedal exhausts air when pedal is released. If it does not, check the line for blockage, and inspect the switch for defect.

8.7.3 Check the outlet muffler that is located inside the cabinet, for blockage.

8.7.4 Check 4-way air valve for jamming per Paragraphs 8.10.4 and 8.10.5.

8.7.5 Check for blockage in the screen in the optional abrasive trap.

8.8 Heavy media flow

8.8.1 Make sure the choke valve is open.

8.8.2 Media metering valve open too far. Adjust per Section 5.2. If adjusting the media valve does not regulate media flow, empty the machine, depressurize the machine, and inspect the internal parts of the valve for wear.

8.9 Media surge: A small amount of surge is normal at start-up.

8.9.1 Heavy media flow. Adjust per Section 5.2

8.9.2 Empty the blast machine, depressurize the blast machine, and inspect the internal parts of the metering valve for wear.

8.10 Air only (no media) comes out the nozzle

8.10.1 Make sure the machine contains media.

8.10.2 Make sure the media metering valve is not closed.

8.10.3 Check for minor blockage in the media metering valve by fully opening the metering valve, and closing the choke valve. Activate the foot pedal to blow out obstructions. If this procedure fails, depressurize the machine, open the metering valve clean out cap and check for foreign objects.

8.10.4 Check the muffler on the 4-way air valve. Air should exhaust from the muffler when the foot pedal is pressed. If air does not exhaust, remove the muffler and try again. If air exhausts now, the muffler is blocked. If air still does not exhaust, the 4-way valve may be faulty, refer to Paragraph 8.10.5 to check the 4-way valve.

8.10.5 Check the 4-way valve as follows: Depressurize the air supply line. Remove the tubing leading to either the media metering valve or diaphragm outlet valve. Pressurize the air supply line. No air should exhaust from the tube adaptor. Press the foot pedal, air should start exhausting at the adaptor, and stop when pressure on the pedal is released. If it does not operate accordingly, the 4-way valve is faulty or air supply is insufficient.

8.10.6 Outlet valve not sealing. Inspect diaphragm.

8.10.7 Metering valve requires service. Refer to the media metering valve manual.

8.11 Blast machine will not pressurize

8.11.1 Make sure the air compressor is on and air supply valves are open.

8.11.2 Make sure the pressure regulator is not turned down. Minimum pressure is 40 psi. See Section 5.1.

8.11.3 Door interlocks not engaging. Check door interlock adjustment per Section 5.5.

8.11.4 Inadequate air supply. Refer to the table in Figure 5.

8.11.5 Inspect diaphragm in the outlet valve for wear.

8.11.6 Inspect pop-up valve and seat for wear and alignment.

8.11.7 Blocked or leaking control line. Check all fittings and urethane tubing for blockage or leaks.

8.11.8 Foot pedal valve malfunction. Check foot pedal for alignment, and inlet and outlet lines for pressure.

8.11.9 Make sure the lines are not reversed on the foot pedal or pilot regulator. Refer to the schematic in Figure 7.

8.11.10 Check the 4-way valve per Paragraphs 8.10.4 and 8.10.5.

8.11.11 Inspect the check valve for obstruction or broken flap.

8.12 Static shocks

8.12.1 Cabinet and/or operator not grounded. Abrasive blasting creates static electricity. The cabinet must be earth-grounded to prevent static build-up. Refer to Sections 2.10 and 2.4.1. If shocks persist, the operator may be building up static. Attach a small ground wire such as a wrist strap, from the operator to the cabinet.

8.12.2 Avoid holding parts off the grate. Static will build-up in the part if not dissipated through the metal cabinet.

8.13 Dust leaking from dust collector

Refer to the reverse pulse dust collector manual for service of reverse-pulse dust collectors.

8.13.1 Check for damaged or loose filters.

8.13.2 Check for a faulty seal on the dust drawer.

8.13.3 Make sure upper and lower tube sheets are sealed on both sides, the front, and rear.

9.0 ACCESSORIES AND REPLACEMENT PARTS

9.1 Optional Accessories

Turntables and Turntables with Tracks

WARNING

Turntable capacities are based on concentric loading. Use solid fixturing to hold heavy parts in place. Do not remove lift equipment until the part is adequately supported to prevent movement. Moving or rotating heavy, unsupported or off-centered parts may cause them to shift or topple, and cause severe injury.

Fixed-base Turntable with Bearing, 500 lb. Capacity, Figure 22

Item	Description	Stock No.
Fixed-base Turntable Assembly, 500 lb. Capacity		
(-)	30" diameter	14138
(-)	40" diameter	24042
(-)	48" diameter, for BNP 7212 only	13845
1.	Turntable, replacement	
	30" diameter 500 lb. capacity	21390
	40" diameter 500 lb. capacity	23879
	48" diameter 500 lb. capacity	21400
2.	Bearing, 1-1/2" bore (48" table requires 2)..	11517
3.	Protector, bearing	13479
4.	Screw, 1/2-NC x 1-1/2" cap	03454
5.	Lock-washer, 1/2"	03516
6.	Nut, 1/2-NC hex	03511

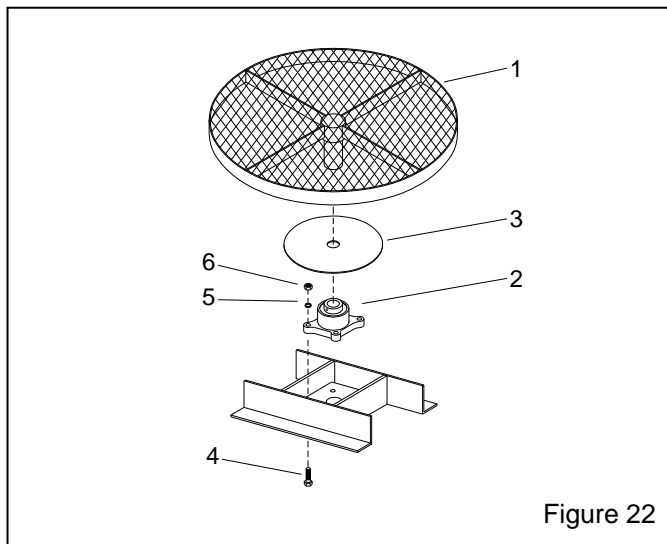
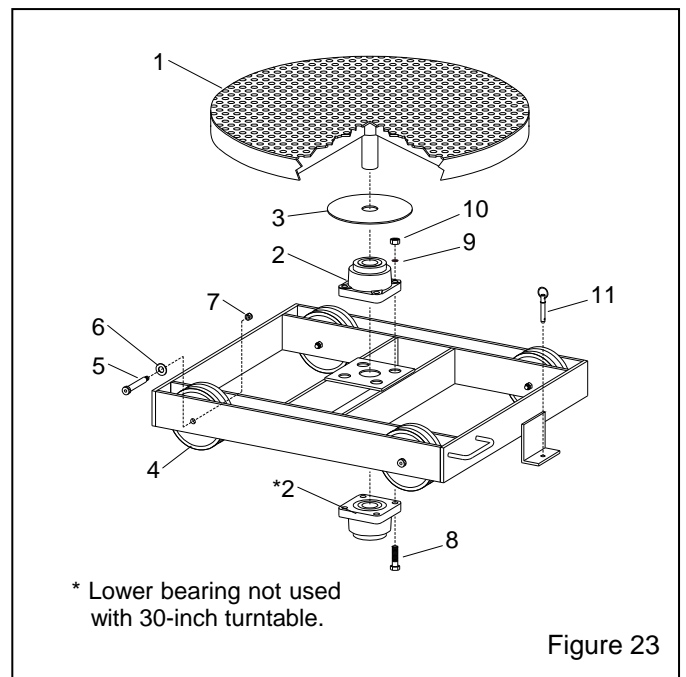

Figure 22

2000 lb. capacity turntable mounted on work cart with 9 ft. (nominal) track extension	
30" diameter for BNP 6012	25550
48" diameter for BNP 6012	27055
48" diameter for BNP 7212	25555

Turntable with Work Cart, 2000 Capacity, Figure 23

Item	Description	Stock No.
1.	Turntable, replacement	
	30" diameter for BNP-6012 and 7212 ...	27727
	48" diameter for BNP-7212 and 7212 ...	27728
2.	Bearing, 1-1/2" bore, 1 req'd for 30" table	
	2 req'd. with 48" table.....	11517
3.	Protector, bearing	13479
4.	Wheel, 6" V groove	12220
5.	Bolt, 1/2" shoulder	13477
6.	Washer, 1/2" flat.....	03515
7.	Nut, 3/8 lock	03312
8.	Bolt, 1/2-NC	
	2" long for 30 inch turntable	03456
	2-1/2" long for 48-inch turntable	03457
9.	Washer, 1/2" lock	03516
10.	Nut, 1/2-NC hex	03511
11.	Pin, quick release	25540



* Lower bearing not used with 30-inch turntable.

Figure 23

Accessories

Description	Stock No.
Conversion kits, Sentinel metering valve	
To convert from fine mesh media to coarse	22848
To convert from coarse mesh media to fine	22849
Rubber curtain set, black	
for 6012	22373
for 7212	22374
Rubber curtain set, white	
for 6012	23528
for 7212	23529
Storage segment, 16": Fits between the reclaimer and blast machine. Provides nearly 2 cubic feet of additional media storage	21128
Flex hose, heavy-lined, for heavy usage with aluminum oxide. Available in 15' lengths only	
4" ID. for 900 cfm	12473
5" ID. for 1200 cfm	12465
6" ID. for 900 cfm	12457
7" ID. for 1200 cfm	12459
Boron nozzle	
CTB-2, 1/8" orifice	21090
CTB-3, 3/16" orifice	21091
CTB-4, 1/4" orifice	21092
Aluminum oxide kit: Includes 3/16" boron carbide nozzle, heavy-lined flex hose, black rubber curtains with eyelets and curtain hardware. NOTE: Reclaimer wear plates are standard on current reclaimers. If the existing wear plate is worn, order a separate wear plate listed in this section.	
6012 w/ 900 cfm	25493
6012 w/ 1200 cfm	25495
7212 w/ 900 cfm	25518
7212 w/1200 cfm	25520
Wear plate kit	
for 900 cfm reclaimer	14055
for 1200 cfm reclaimer	19223
for 1800 cfm reclaimer	23028
Vortex cylinder assembly, externally adjustable for use with fine-mesh or lightweight media.	
for 900 cfm exhauster mounted reclaimer	23047
HEPA Filter, for use with reverse pulse dust collectors	
900 cfm free standing	23626
1200 cfm free standing	23627
Lock pins (package of 25) for twist-on type hose couplings	11203
Time delay door lock	23164
Safety cable, 1/2" hose	15012
Manometer kit	12528
Armrest assembly	24900

Supa hose, 3/4" ID x 25 feet, uncoupled 21121
 NOTE: Supa hose requires the use of contractor thread nozzle holder and nozzle.

Nozzle holder w/contr. thread, for 3/4" Supa hose... 11398
 Coupling, for 3/4" Supa hose 11395
 Gasket, coupling for 3/4" Supa hose 08415

Nozzle, short venturi for use with Supa hose
 TYP-3, 3/16" orifice 23501
 TYP-4, 1/4" orifice 23502
 TYP-5, 5/16" orifice 23503

9.2 Abrasive Trap, Figure 24, Optional

Item	Description	Stock No.
(-)	Abrasive trap, complete	02011
1.	Screen	02012
2.	O-Ring	02013
3.	Cap	02014
4.	Body	02015
5.	Lock bar	02016
6.	Screw, 3/8" x 1" thumb	03289
7.	Shoulder screw, 3/8" x 3/8"	03291
8.	Gasket, screen	02434
9.	Decal	02129
(-)	Service kit (items 1, 2, 8 and 9)	01925

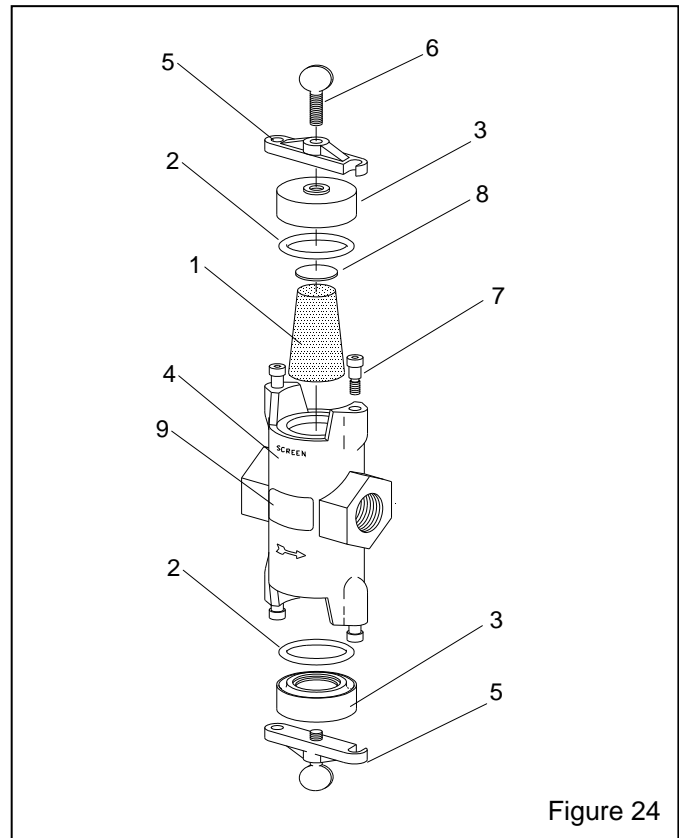

Figure 24

9.3 Cabinet Replacement Parts, Figure 25

Item	Description	Stock No.
1.	Gasket, door, adhesive backed 6012 req'res 24 ft., 7012 req'res 28 ft. ..	21236
2.	Light assembly	25300
3.	Window glass, 20" x 30"	12213
4.	Gasket, 5/16" x 3/4", applied to cabinet per foot, 9 feet required	00189
5.	Gasket, 5/32" x 3/4", applied to window frame per foot, 9 feet required	00192
6.	Cover lens, 20" x 30", pkg. of 5	23232
7.	Nut, plastic, window frame, 2 required	23035
8.	Grate, slotted front for 6012	25155
	for 7212	12971
9.	Grate, unslotted for 6012	25154
	for 7212 (3 required)	12970
10.	Glove set	11215
11.	Glove, left hand only	12710

12.	Glove, right hand only	12711
13.	Clamp, glove.....	11576
14.	Grommet, blow off hose	11798
15.	Grommet, blank	11798
16.	Support adaptor, blast hose	16554
17.	Foot pedal assembly, less tubing	20483
18.	Muffler, outlet	05068
19.	Actuator bracket, adj., door interlock	19152
20.	Over-travel stop, door interlock	20004
21.	Detent sleeve, door interlock	15042
22.	Valve, 3 way air, door interlock	12202
23.	Eyebolt, 5/8"	13421
24.	Regulator, 1/8" NPT pilot	12715
25.	Gauge, pressure	01908
26.	Gasket, 5/16" x 1" adhesive backed, Specify feet required	00187
27.	Gasket, blast hose support adaptor	13426
28.	Glass w/frame, replacement	25301
29.	Intake stack w/damper	23156
30.	Baffle, air intake	25912

Refer to the electrical schematic for electrical parts

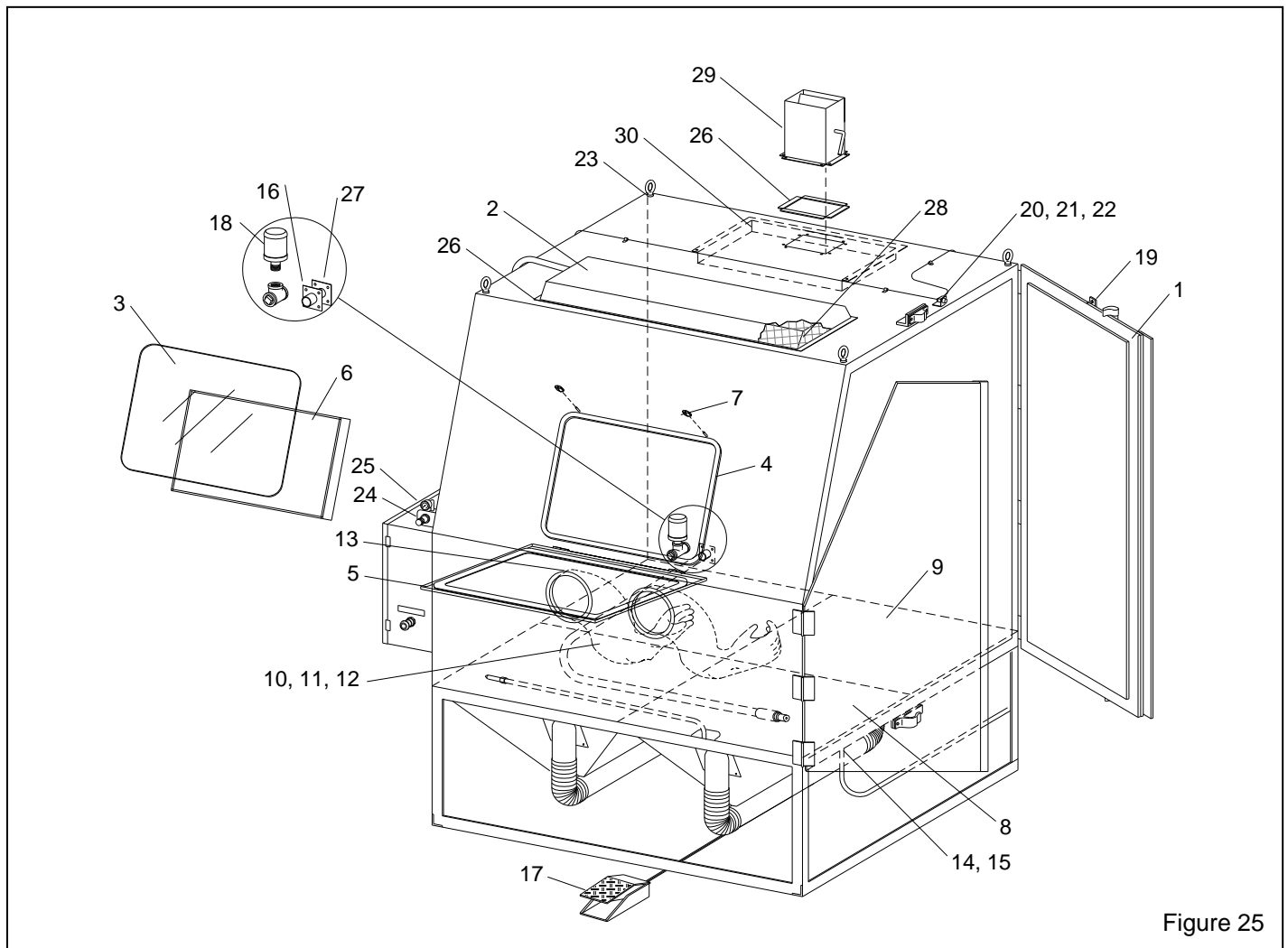
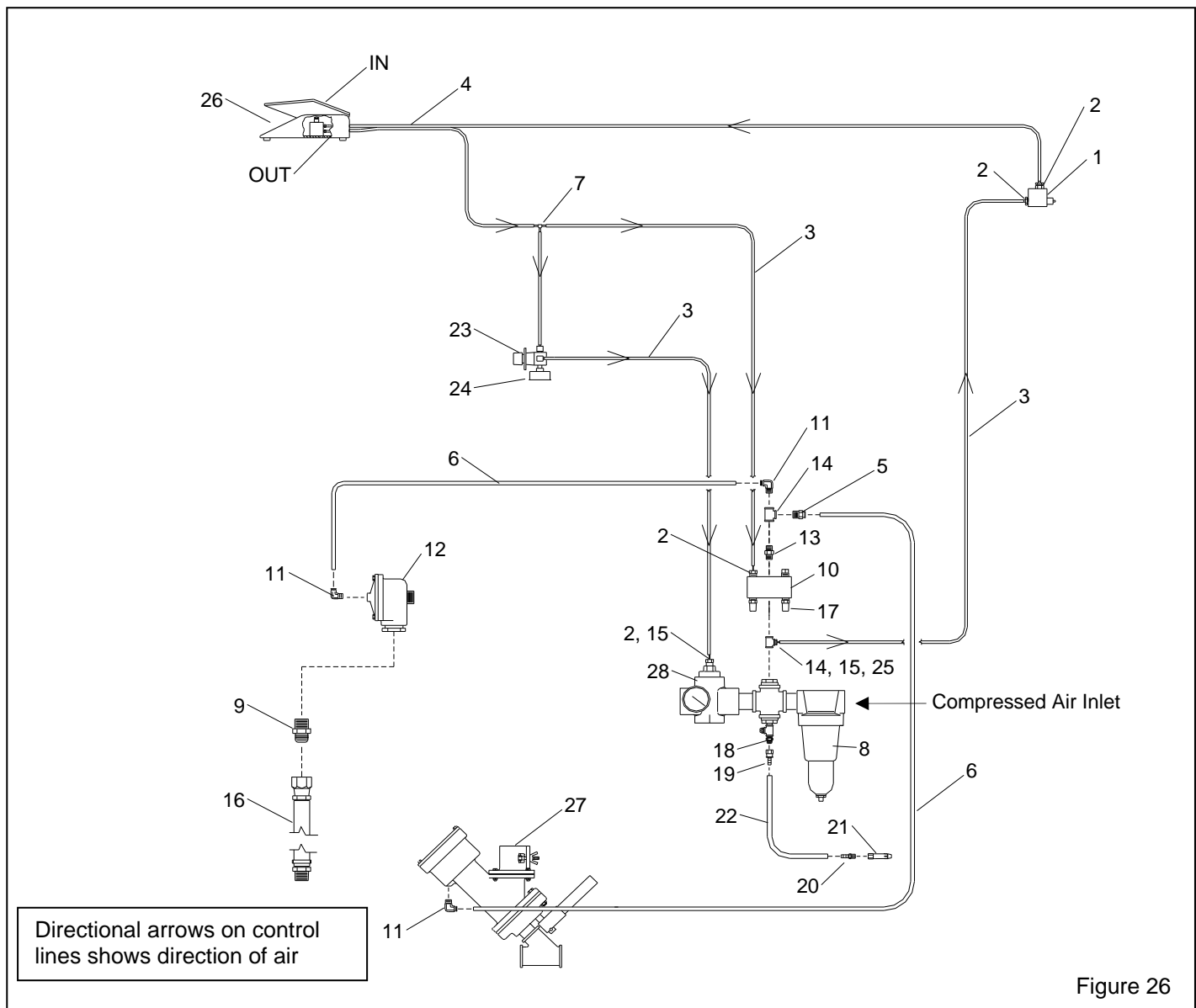

Figure 25

9.4 Plumbing and Air Schematic, Figure 26

Item	Description	Stock No.
1.	Valve, 3 way	12202
2.	Adaptor, 1/8" NPT x 1/8" barb	11732
3.	Tubing, 1/8" ID urethane, specify ft. reqd. ..	12475
4.	Tubing, 1/8" ID twin urethane specify feet required	19577
5.	Adaptor, straight 1/4" NPT x 3/8 tube	11736
6.	Tubing, 3/8" OD poly, specify feet req'd ...	12478
7.	Tee, 1/8" tube barb	11734
8.	Filter, 1" w/ auto drain	22425
9.	Adaptor, 1" male NPT x 1" male flare	11720
10.	Valve, 4-way air	12203
11.	Adaptor, elbow 1/4" male NPT x 3/8 tube ..	11685
12.	Valve, diaphragm outlet	03371
13.	Nipple, 1/4" Hex	02808

14.	Tee, 1/4" brass	02025
15.	Bushing 1/4" x 1/8" NPT	02010
16.	Hose assembly, 1" x 10' exhaust	23915
17.	Muffler, 1/4" bronze	03988
18.	Adaptor, 1/2" NPT x 1/2" male flare	11351
19.	Hose end, 1/2" barb x 1/2" female swivel ...	15002
20.	Hose end, 1/2" barb x 3/8" male NPT	06369
21.	Blow-off nozzle	13116
22.	Hose, 1/2" ID air, specify feet required	12472
23.	Regulator 1/8", pilot	12715
24.	Gauge, pressure	01908
25.	Adaptor, 1/8" NPT elbow x 1/8" barb	11733
26.	Foot pedal assembly, less tubing	20483
27.	Media metering valve, Sentinel for 50 mesh and finer media	21439
	for 50 mesh and coarser media	20608
28.	Regulator, 1" pilot operated w/ gauge	12052



9.5 Sentinel Valve Replacement Parts

Refer to the Sentinel valve owner's manual for replacement parts.

9.6 Blast Machine and Accessories, Figure 27

Item	Description	Stock No.
(-)	Blast Machine Assembly, 2 cu. ft. capacity, Complete	21135
1.	Ball valve, 1" with handle (choke valve)	02396
2.	Handle, 1" ball valve	22531
3.	Leg pad, right for 1642	20735
4.	Leg pad, left for 1642	20736
5.	Adaptor, 1" male NPT x 1" male flare	11720
6.	Hose assembly, 1" x 21" pusher line	22508
7.	CF Coupling, 1-1/4"	00551
8.	Media metering valve, Sentinel for 50 mesh and finer media	21439
	for 50 mesh and coarser media	20608
9.	Inspection door assembly, 6" x 8"	02377
10.	Gasket, 6" x 8" inspection door	02369
11.	Pop-up valve with external sleeve	03699

12.	Guide 1-1/4" x 6" toe	01722
13.	Seat, pop-up valve	02325
14.	Outlet valve, 1" diaphragm	03371
15.	Regulator, 1" pilot operated w/ gauge	12052
16.	Gauge, 1/4" cbm	11830
17.	Filter, 1" w/ auto drain	22425
18.	Check valve, 1" swing	12187
19.	Gasket, CQG, Pkg. of 10	00850
20.	Coupling, 1/2" blast hose, CQA-1/2	00599
21.	Valve, 4-way air (valve only)	12203
22.	Nozzle holder, CHE-1/2	00577
23.	Blast hose, 1/2" x 16' coupled includes items 20, and 22	01251
24.	Nozzle, tungsten carbide CT-2, 1/8" orifice	01351
	CT-3, 3/16" orifice, std.	01352
	CT-4, 1/4" orifice	01353
25.	Nozzle washer, NW-1, pkg. of 10	21580
26.	Adaptor, elbow 1/4" male x 3/8" tube	11685
27.	Adaptor, straight 1/4" male x 3/8" tube	11736
28.	Muffler, 1/4" bronze	03988
29.	Hose assembly, 1" x 10' exhaust	23915
30.	Lock pin, coupling (package of 25)	11203

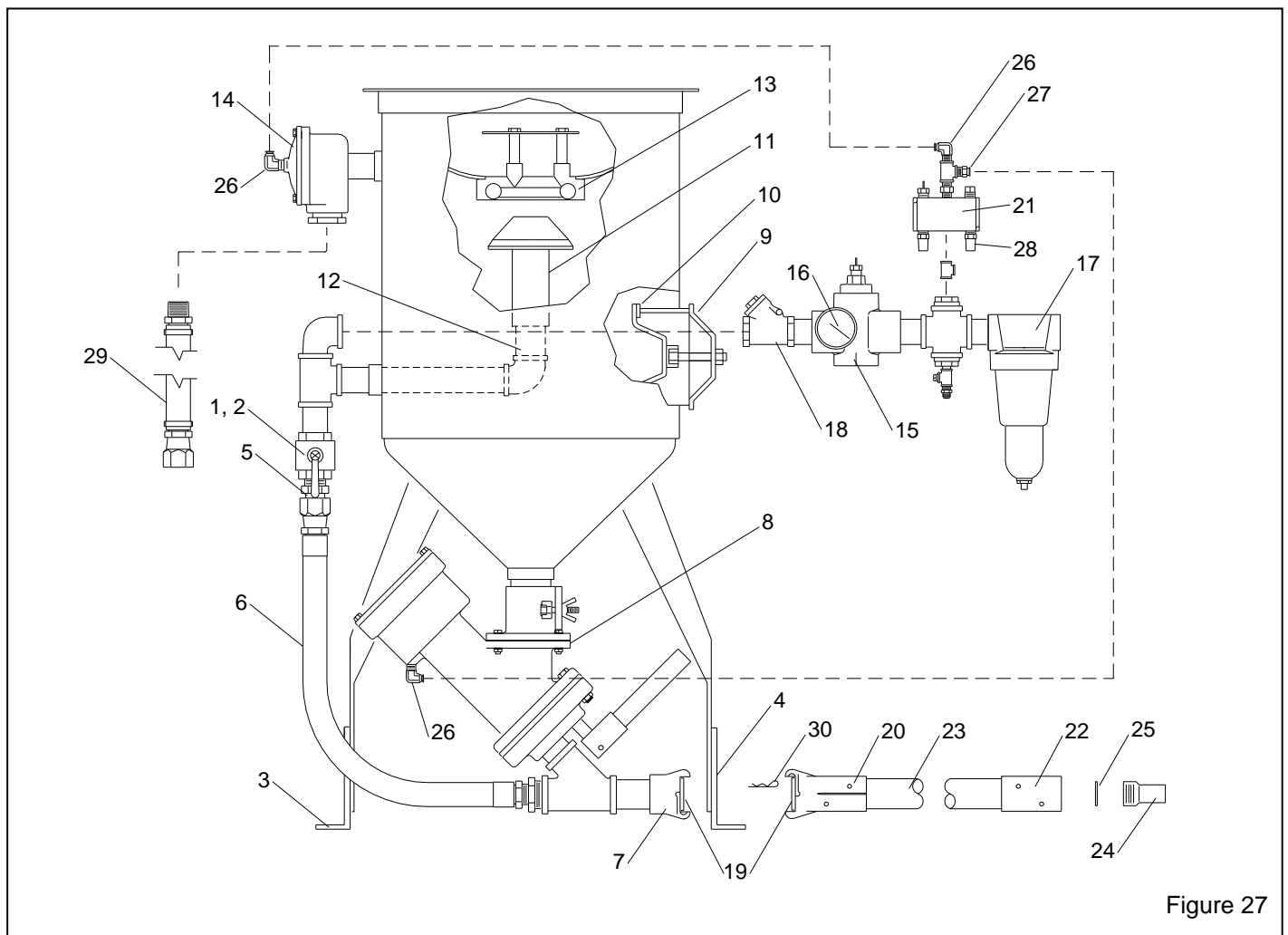
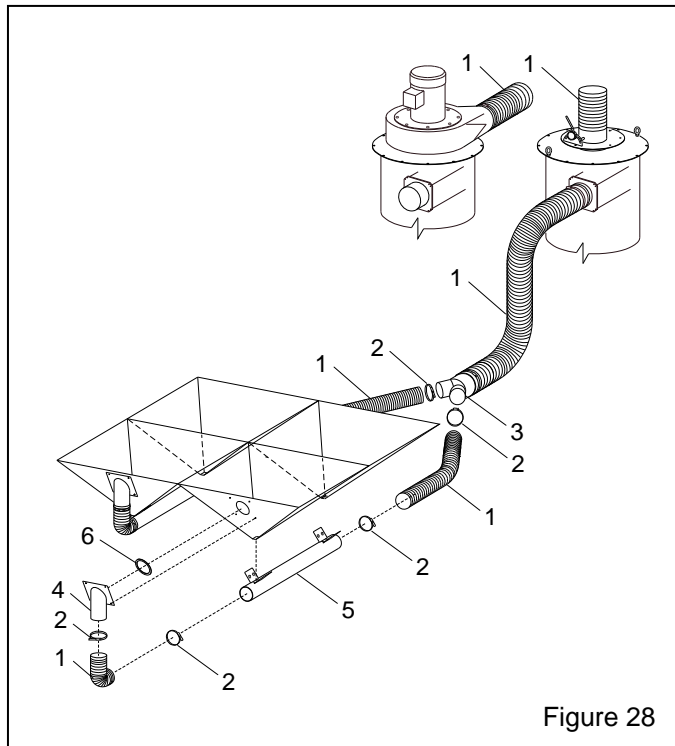

Figure 27

9.7 Flex Hose, Pipe, and Adaptors, Figure 28

Item	Description	Stock No.
1.	Hose, light-lined flex, specify length required.	
	4" ID	12466
	5" ID	12467
	6" ID	12468
	7" ID	12469
	8" ID	12470
	12" ID	12460
2.	Clamp, hose	
	for 4" hose	11577
	for 5" hose	11578
	for 6" hose	00750
	for 7", 8", and two for 12" hose	11576
3.	Wye Pipe adaptor	
	two 4" x one 6"	12379
	two 5" x one 7"	16939
	Consult local distributor for larger sizes	
4.	Air intake adaptor, hopper, each	
	4" for 900 cfm	24526
	5" for 1200 cfm	24527
	6" for 1800 cfm	24528
5.	Hopper pipe, bolt on, each	
	4" for model 6012, 900 cfm	24517
	5" for model 6012, 1200 cfm	24518
	6" for model 6012, 1800 cfm	24519
	4" for model 7212, 900 cfm	24534
	5" for model 7212, 1200 cfm	24535
	6" for model 7212, 1800 cfm	24536
6.	Gasket, 5/16" x 1" adhesive backed,	
	Specify feet required	00187



9.8 1" Diaphragm Outlet Valve, Figure 29

Item	Description	Stock No.
(-)	1" Diaphragm outlet valve, complete	03371
1.	Nipple, 1" x close	01701
2.	Diaphragm, outlet valve	06149
3.	Lock washer, 1/4"	03117
4.	Cap screw, 1/4"x 1"	03053
5.	Cap, diaphragm outlet	03393
6.	Body, diaphragm outlet	06135
7.	Bushing, 1-1/4" x 1"	01804

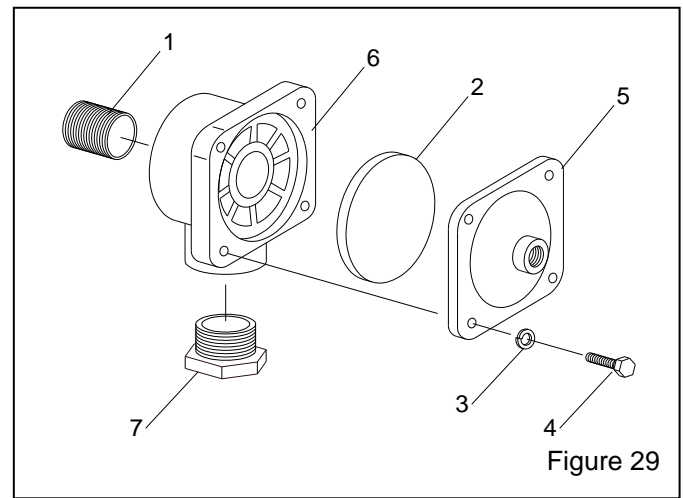

9.9 Foot Pedal Assembly, Figure 30

Item	Description	Stock No.
(-)	Foot pedal assembly, less tubing	20483
1.	Top, foot pedal	20017
2.	Base, foot pedal	19991
3.	Valve, 3 way n/c	20026
4.	Drive pin, grooved	20109
5.	Screw, 1/4 nf x 3/4" soc. hd.	03086
6.	Screw, 10-32 x 1/2" fh	19571
7.	Adaptor, 10-32 thrd. x 1/8 barb	11731
8.	Spring, 1-1/4" x 3-1/2"	20121
9.	Screw, 8-32 x 3/8" thread cut	11389
10.	Bumper, rubber	21522

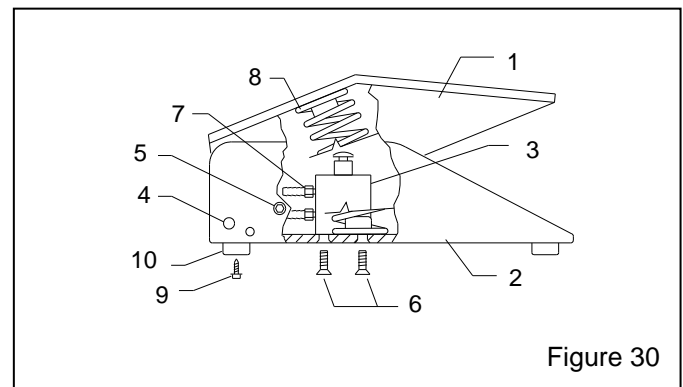

9.10 Reclaimer, Figure 31

NOTE: Exhauster components, Items 1 - 4, are not shown for 1200 and 1800 cfm reclaimers, because exhauster equipped reverse pulse dust collectors are used with those reclaimers.

Item	Description	Stock No.
(-)	Reclaimer assembly, push-thru, 16" flange less exhauster or vortex 900 cfm	21252
(-)	Reclaimer assembly, push-thru, 16" flange with exhauster, less vortex 900 cfm	21253
(-)	Reclaimer assembly, pull-thru, 16" flange with externally adjustable vortex cylinder 900 cfm	21293
	1200 cfm	24066
	1800 cfm	Consult local distributor
1.	Motor, exhauster for 900 cfm reclaimer, 2 HP, 3-Ph	12309
2.	Plate, motor mount, 900 cfm	12005
3.	Housing, 900 cfm exhauster	12271
4.	Paddle wheel, 900 cfm	12335
5.	Gasket, 5/16" x 1" adhesive backed, specify feet required	00187
6.	Inlet pipe adaptor, 900 cfm, 6"	12363
7.	Gasket, inlet adaptor 900 cfm	11759
	1200 cfm	11767
	1800 cfm	11765

8.	Wear plate, rubber lined w/mtng screws 900 cfm	25071
	1200 cfm	19223
	1800 cfm	23028
9.	Screen assembly, No. 8-mesh	21265
10.	Gasket, door 900 cfm	11745
	1200 cfm and 1800 cfm	11766
11.	Spring latch assembly	12263
12.	Hose support, inlet 900 cfm, 6", optional	16887
	1200 cfm, 7", standard	20596
	1800 cfm, 8", standard	20597
13.	Vortex cylinder assembly, for 900 cfm exhauster mounted reclaimer (optional) ...	23047
14.	Vortex cylinder assembly, adjustable, standard with pull-thru reclaimer 900 cfm, 7"	23046
	1200 cfm, 12"	25432
	1800 cfm, 12"	19090
15.	Gasket, 2" adhesive backed, specify feet required	13089
16.	Top plate 900 cfm	23040
	1200 cfm	24057
17.	Hose support, outlet, optional 900 cfm	20619
	1200/1800 cfm	20730
18.	Hopper, 900 cfm pressure, 16" flanged	23043

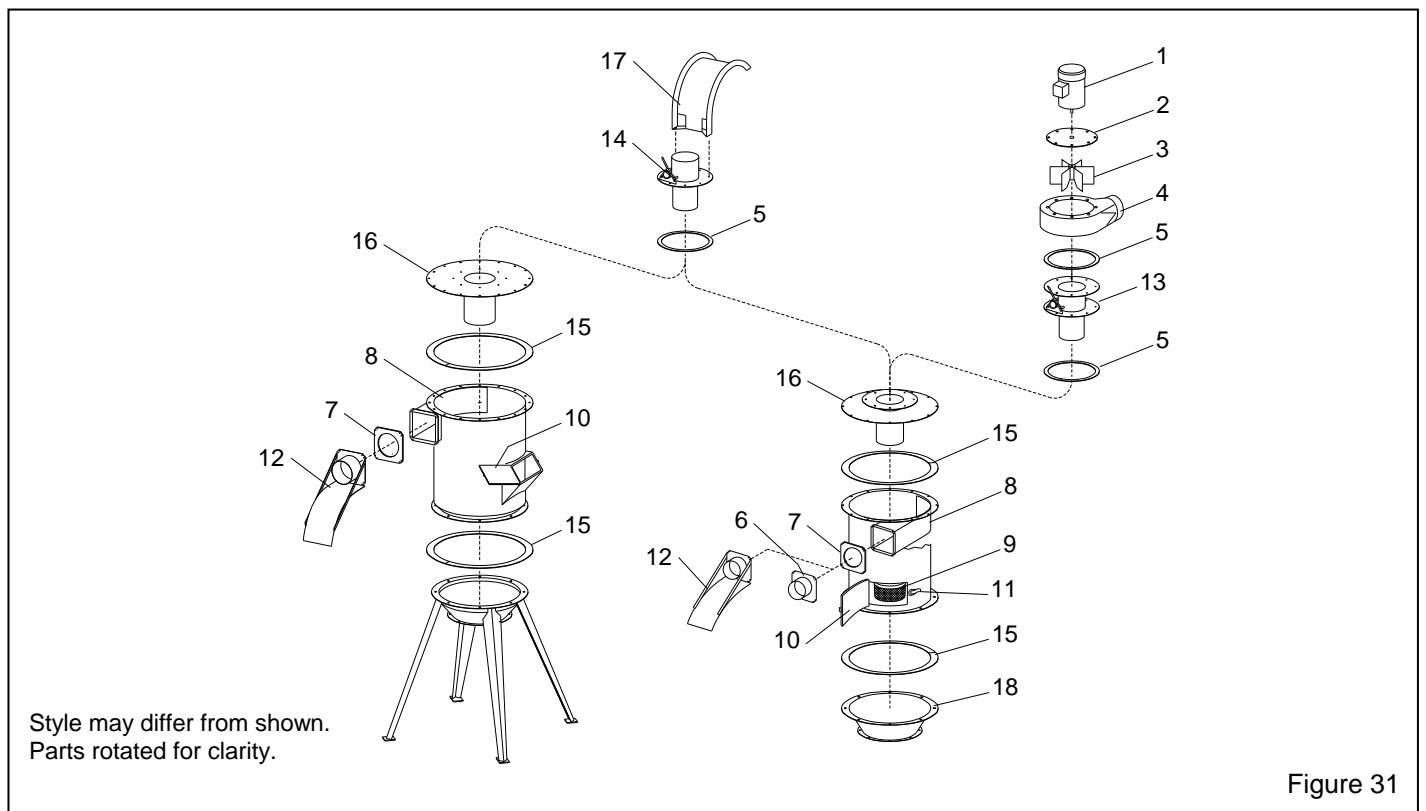

Figure 31

9.11 Reclaimer Liners, Figure 32
 Reclaimer must be designed for liners and have a removable top.

Item	Description	Stock No.
(-)	Rubber liner sets	
	900 cfm	23151
	1200 cfm	25439
	1800 cfm	23153
1.	Top liner	
	900 cfm	23059
	1200 cfm	22689
	1800 cfm	22695
2.	Baffle, lined	
	900 cfm (2-piece).....	23416
	1200 cfm	24654
	1800 cfm	22696
3.	Side liner, reclaimer body	
	900 cfm	17008
	1200 cfm	25436
	1800 cfm	22697
4.	Inlet side liner	
	900 cfm	12830
	1200 cfm	22693
	1800 cfm	22698
5.	Inner cone liner	
	900 cfm	16070
	1200 cfm	22694
	1800 cfm	22699
6.	Inlet top	
	900 cfm	22827
	1200 cfm	24031
	1800 cfm	24032
7.	Screw, self-drilling, 10-16 x 3/4"	12722

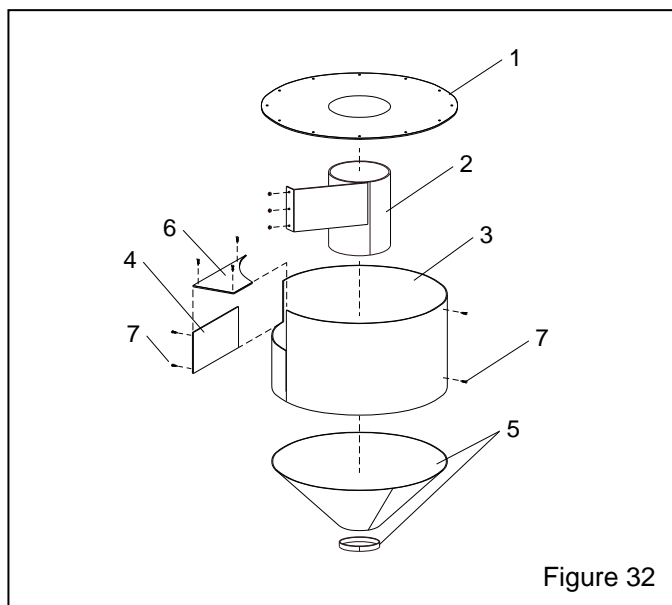

Figure 32

9.12 Dry Filter Dust Collector, Figure 33

Item	Description	Stock No.
(-)	Dry filter, complete 900 cfm	12701
1.	Inlet adaptor w/ damper, 7" for 900 cfm	14273
2.	Gasket, inlet adaptor, 900 cfm	11763
3.	Gasket, dust drawer	11771
4.	Spring latch assembly	12263
5.	Drawer, dust, 900 cfm	14276
6.	Plate, inlet cover, for 900 cfm	14278
7.	Tubular filter, each, 900 cfm requires 40 ..	11503
8.	Shaker, tube filter, 900 cfm	12415
9.	Handle, shaker	12899

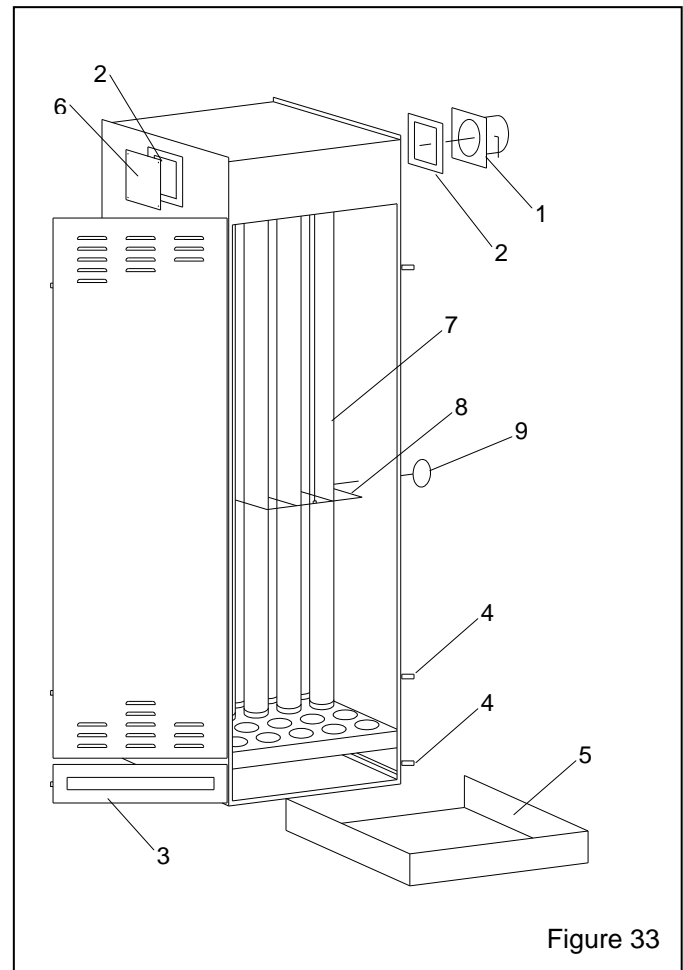

Figure 33