

CE0194

ISO9001
CERTIFIED COMPANY



rpb® **PX4 AIR PAPER**
INSTRUCTION MANUAL

rpb® **PX4 AIR PAPER**

CONTENTS

Read all instructions and warnings before using this product.
Keep this manual for future reference.

INTRODUCTION	3
PAPER COMPONENT CONCEPT	5
WARNINGS	6
RESPIRATOR OPERATIONS	8
PAPER SETUP AND USE	10
APPARATUS CLASSIFICATION AND PROTECTION FACTOR	18
RESPIRATOR OPERATIONS (CONTINUED)	19
PRODUCT SPECIFICATIONS AND DATA	21
TROUBLE SHOOTING	22
PARTS AND ACCESSORIES	24
PARTS LIST	25

RPB® Safety Global Headquarters 2807 Samoset Rd, Royal Oak, MI 48073, USA.
T: 1-866-494-4599 F: 1-866-494-4509 E: sales.us@rpb-safety.com **rpb-safety.com**

RPB® Safety Asia Pacific Headquarters 652 Halswell Junction Road, Hornby South 8042
New Zealand. T: +64-3-357-1761 F: +64-3-357-1763 E: sales.nz@rpb-safety.com **rpb-safety.com**

RPB®, Advancing Your Safety, Nova, Nova 3, Radex, and Zytec are registered trademarks of RPB® Safety LLC

For technical assistance contact our Customer Service Department
on 1-866-494-4599 or email: customerservice@rpb-safety.com

Form #: 7.20.526
Rev: 0

INTRODUCTION

The RPB® PX4 AIR is approved in two configurations, 03-911 to EN 12941: 1998 + A1: 2003 + A2: 2008 as a Powered Air Purifying Respirator Fan Unit only when used in conjunction with the following Respirators:

- Nova 3 Respirator - (EN 12941: 1998 + A1: 2003 + A2: 2008 TH3 P R SL)
- Z3 Welding Respirator - (EN 12941: 1998 + A1: 2003 + A2: 2008 TH2 P R SL)

This Respirator System is intended to be used only in conjunction with an “Organised Respiratory Protection Program” which complies with the Requirements of National and Local Governments.

The RPB® PX4 AIR belt mounted assembly consists of a motor/blower unit, high efficiency filter, waist belt and lithium ion battery pack. The motor/blower unit draws ambient air through its high efficiency filter and supplies air to the headgear via a breathing tube. The blower unit is equipped with automatic flow control; the motor speed is monitored and regulated during operation to compensate for the charge state of the battery pack and the increasing level of airflow resistance caused by filter blocking. Should the airflow fall below the minimum flow rate an audible alarm will sound and the fan

indicator light bar will turn red and flash on the control panel. The user should leave the work area immediately should this occur. In like manner, the Battery indicator bar will turn red and sound the audible alarm when the battery has approximately 10 -15 minutes of charge left, to give sufficient warning to the wearer that the power will shut off soon.

When selecting a Powered Air Purifying Respirator (PAPR), the following factors need to be considered:

1. Possible occurrence of explosive atmosphere.
2. Types of pollutants.
3. Concentrations.
4. Intensity of work.
5. All other protective requirements other than respiratory.

All risk analysis should be carried out by a person trained to make suitable decisions on these matters.

The RPB® PX4 AIR has been designed for use in atmospheres that are NOT IMMEDIATELY DANGEROUS TO LIFE OR HEALTH (IDLH).

The RPB® PX4 AIR 03-911 are approved to EN 12941: 1998 + A1: 2003 + A2: 2008 TH2/TH3 P R SL for use in environments where hazards are known and characterized and oxygen deficiency is not present. It is only approved in the

rpb® PX4 AIR PAPER

configurations indicated on page 4 of the manual. Refer to the Instruction Manual provided with the appropriate RPB® Respirators for more information.

Note: the EN 12941: 1998 + A1: 2003 + A2: 2008 standard is a requirement for loose fitting respirators such as helmets and face shields (03-911) and the 12942: 1998 + A1: 2004 + A2: 2008 standard is a requirement for tight fitting respirators such as full face masks and half face masks (03-912 Low Flow). For more information on the respirator refer to the specific Respirators User Instruction Manual.

Service Life of HE Filter, Prefilter and Spark Arrestor

The HE filter should be replaced if the airflow alarm is activated, or the flow indicator reading falls below the 6cfm (170 slpm) for the 03-911 and 4.2cfm (120 slpm) for 03-912 minimum airflow. The HE filter should also be replaced if there is damage to the filter media, such as a tear or puncture, etc... or the filter media becomes wet. The PX4 AIR is approved to only be used with genuine RPB® filter cartridges.

The Prefilter is recommended to be replaced when it is dirty or damaged or at the same time as the HE Filter. The Spark Arrestor should be replaced if it becomes damaged or clogged with debris.

WARRANTY

All RPB® products are covered by a manufactures warranty of 3 months. The manufacturer warranty covers defects in material, workmanship and does not cover damage caused by misuse or abuse. RPB®'s only obligation and your exclusive remedy shall be to repair, replace or refund the purchase price of such parts or products upon the presentation of proof of purchase. Maximum liability is in no case to exceed the value of the RPB® Product involved.

APPROVAL

The RPB® PX4 AIR meets the requirements of the European Community Directive 89/686/EEC, (Personal Protective Equipment Device).

The RPB® PX4 AIR is approved as an EN 12941: 1998 + A1: 2003 + A2: 2008 TH2/ TH3 P R SL Respirator by:
Apave Sudeurope SAS (0082)
8 rue Jean-Jacques Vernazza
CS 60193
13322 Marseille Cedex 16
France

Under Article 10 and the quality systems are approved under Article 11b by INSPEC International (0194)
Salford University Business Park
56 Leslie Hough Way
Salford M6 6AJ
United Kingdom

PAPR COMPONENT CONCEPT

The RPB® PX4 AIR is part 3 of the 3 main components that constitute a respirator (Note the T100 has been used in the below diagram as an example):

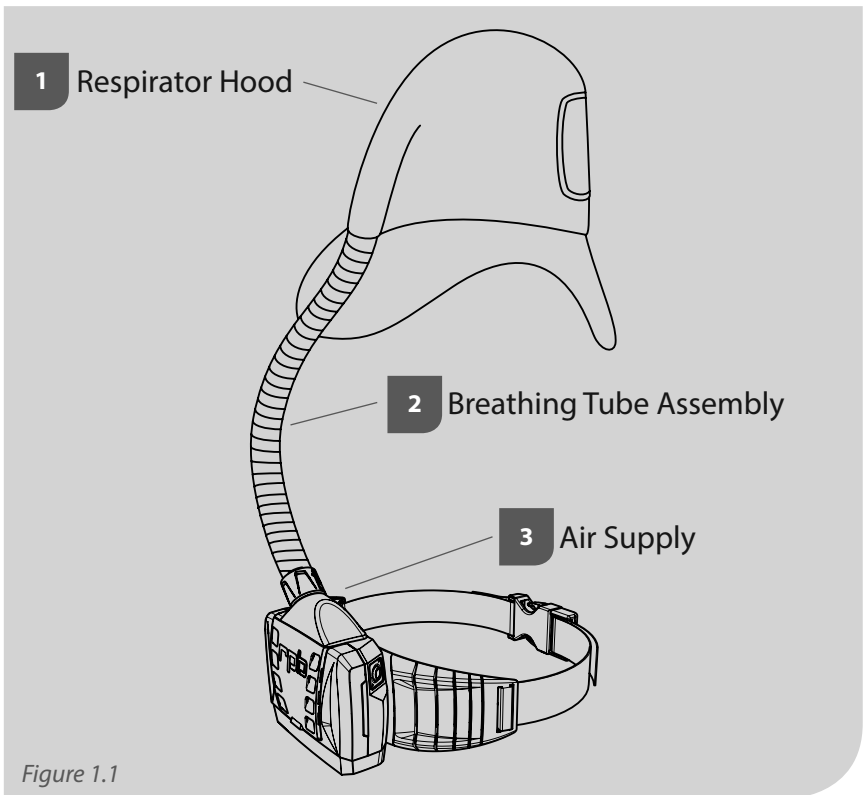

Figure 1.1

!WARNING! Failure to use genuine parts and components that are part of the approved respirator assembly will void the approval of the entire respirator assembly.

rpb® PX4 AIR PAPER

!WARNINGS!

1. Do not use this respirator until you have been trained in the respirators' use, maintenance and limitations by a qualified individual (appointed by your employer) who has extensive knowledge of the RPB® PX4 AIR.
2. Before using this respirator ensure your employer has determined that airborne contaminant concentrations do not exceed those allowed by applicable National and Local Government regulations and recommendations for Power Air Purifying Respirator. Government law requires that the employer measures and monitors airborne contaminant levels in the work area.
3. DO NOT WEAR this respirator if any of the following conditions exist:
 - Atmosphere is immediately dangerous to life or health.
 - You CAN NOT escape without the aid of the respirator.
 - Atmosphere contains less than 19.5% Oxygen.
 - Work area is poorly ventilated.
 - Contaminants are in excess of regulations or recommendations.
4. Do not modify or alter this respirator. Use only parts and components that are part of the EN 12941: 1998 + A1: 2003 + A2: 2008 TH2/TH3 P R SL approved respirator assembly. The use of non RPB® parts voids the EN 12941: 1998 + A1: 2003 + A2: 2008 TH2/TH3 P R SL approval of the entire respirator assembly.
5. Inspect all components daily for signs of damage or wear that may reduce the level of protection originally provided.
6. Do not wear this respirator until you have passed a complete physical exam, maybe including a lung X-ray conducted by qualified medical personnel.
7. Improper use of this respirator may cause injury or death. Improper use may also cause life threatening delayed lung disease such as silicosis, pneumoconiosis or asbestosis.
8. This respirator, when properly fitted and used, significantly reduces but does not completely eliminate the breathing of contaminants by the respirator wearer.
9. DO NOT use this respirator in poorly ventilated areas or confined spaces unless the area is well ventilated and that the contaminant concentrations are below those recommended for this respirator. Follow all procedures for confined space entry, operation and exit as defined in applicable National and Local Government regulations and recommendations.

!WARNINGS! (CONTINUED)

10. The RPB® PX4 AIR PAPR is not intrinsically safe. Do not use in flammable or explosive atmospheres. Doing so may result in serious injury or death.

Always correctly use and maintain the lithium ion battery packs. Failure to do so may cause fire or explosion or could adversely affect the respirator performance and result in injury, sickness or death.

- Do not charge batteries with unapproved chargers, in enclosed cabinets without ventilation, in hazardous locations, or near sources of high heat.
- Do not immerse in water or other liquids.
- Do not use, charge, or store batteries outside the recommended temperature limits.

11. LEAVE WORK AREA IMMEDIATELY IF:

- Any respirator component becomes damaged.
- Airflow stops or slows down
- Breathing becomes difficult
- You become dizzy, nauseous, too hot, too cold, or ill.
- Vision is impaired.
- When the Warning Alarm Sounds

12. The materials that the respirator is made of may create static electricity under low humidity. For

more information on this, please call our Customer Care Team on 1-866-494-4599 or visit rpbsafety.com.

13. For information on the Respirators' head protection properties i.e. EN397, please refer to the respective Respirator's Instruction Manual.
14. For information on the Respirators' hearing protection properties i.e. EN352, please refer to the respective Respirator's Instruction Manual.
15. For information on the Respirators' eye protection properties i.e. EN166, please refer to the respective Respirator's Instruction Manual.
16. Incorrect use could be dangerous. Caution should be taken for the possibility of looped hoses and/or cables becoming caught up.
17. At very high work rates the pressure in the device may become negative at peak inhalation flow.
18. Power off state gives little or no respiratory protection and this is considered an abnormal situation. In the power off state a rapid build-up of carbon dioxide and depletion of oxygen within the hood may occur.

RPB® PX4 AIR PAPER

RESPIRATOR OPERATIONS

Unpacking

Inspect the package contents for shipping damage and ensure all components are present. The product should be inspected before each use following the procedures in the inspection and cleaning section of this Instruction Manual.

Battery Pack

The battery pack must be inspected before each time it is charged. If there are any cracks or evidence of damage to the case do not charge the battery pack. All batteries must be disposed of in a correct and responsible manner, in accordance with local government ordinances.

Before using the RPB® PX4 AIR make sure that the battery is fully charged, as per the following instruction steps on page 10.

Note: For problems with the Battery Pack, see the Trouble Shooting section on Page 22.

High Efficiency (HE) Filter

Before unpacking the 03-985 HE filter make sure that the sealed plastic packaging is still intact. Once the seal is broken the filter is exposed to the environment and may become contaminated. Before inserting the filter make sure that the following points are checked:

1. Check the Fan unit is switched off and the fan is not running before opening the Door.
2. Inspect the filter for tears or any sign of damage to the filter media.
3. Inspect the seal on the back side of the filter is clean and free of cuts or distortions.

Equipment Marking

The RPB PX4 and its filters are marked in accordance with the EN 12941: 1998 + A1: 2003 + A2: 2008 TH2/TH3 P R SL.

TH1, TH2, and TH3 – Indicate the class designation for complete device.

P, R, and SL – reusable Particle Filter against liquid and solid particles.

A1, B1, E1 and A2 Gas Filter class designation

(Note: the "A", "B" and "E" indicates that the filter provides protection against organic, inorganic and acid gases, as per the standard and the number following the letter indicates the filter capacity).

Note: see table 1-1 on page 18 for details on the filter selection.

There are two models of the PX4 AIR:
03-911 - Standard air flow - light gray fan cover
03-912 - Low flow model for tight fitting respirators - Dark Gray fan cover and model label on back.

Markings and Symbols on the Equipment



- Read all instructions before use.

Li-Ion

- Lithium Polymer Batteries.



- Batteries shall be disposed of as electronic waste.



- Recycle



- RoHS compliant.

ALARMS AND DEVICE WARNINGS

Filter Blockage

A pulsing alarm sounds when the airflow to the hood falls below the minimum requirement of 170slpm (180slpm Nominal) for 03-911 and 120slpm (130slpm Nominal) for 03-912 more than 5-10 seconds in duration.

Battery Level

A pulsing alarm sounds when approximately 10-15 minutes of charge is left in the battery. Power the unit off and remove the battery (in a safe area) and place on the charger. If you have a second battery you can connect it to the device to continue operation. The continuous alarm will also sound if the battery is overheating.

Alarm volume is 85 dBA at 4" (104mm).

Note: When the alarm sounds it is recommended that you leave the work area immediately. Once outside of the work area power the unit down and resolve the problem.

When the alarm sounds there will be a vibration activated as well. This will help notify the operator of the warning even in noisy environments or when using hearing protection.

rpb[®] PX4 AIR PAPER

PAPR SETUP AND USE

CHARGING THE BATTERY PACK

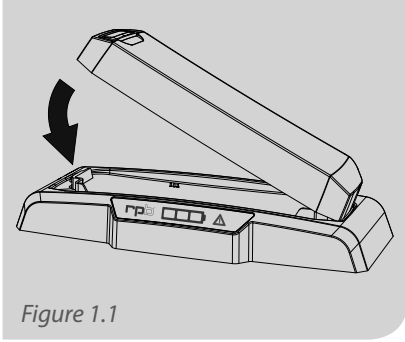

Fit the battery to the charging station by connecting the left side and rotate the battery down and latch into place.

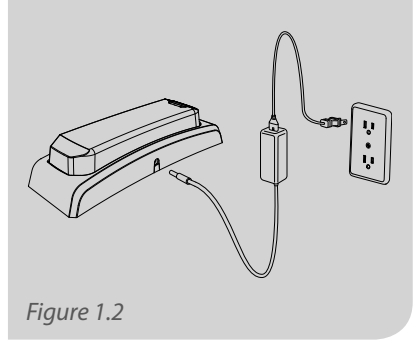

Connect the Power Pack to the charging station. Connect the Power Pack to the Mains Electrical Source (110 - 240v), charging will begin.

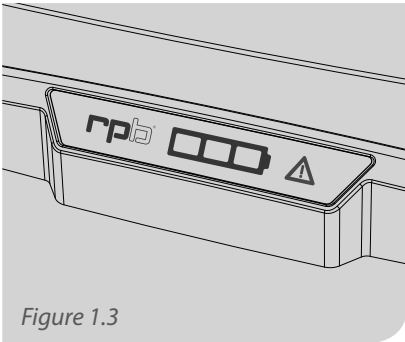

Follow the indicators from left to right on the front of the charging station to know the status of the charge process. The triangle warning light will indicate if there is problem charging. When all three lights display green, the battery is fully charged.

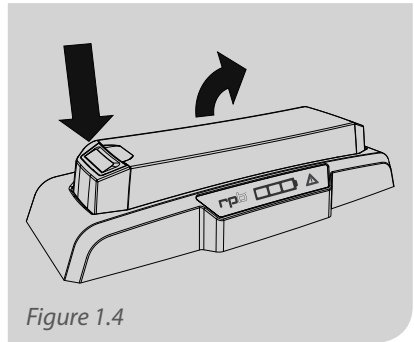

To remove the battery from the charging station, press the release latch on the bottom of the battery and lift the battery from the station.

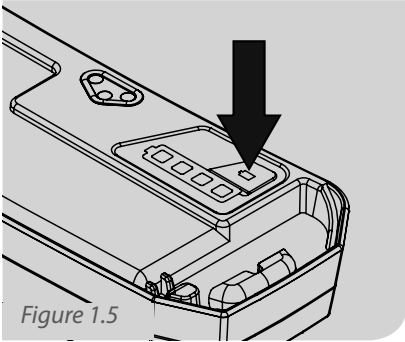

Figure 1.5

The battery has a power capacity indicator showing the level of charge from 20% to 100%, press the test button to reveal the result.

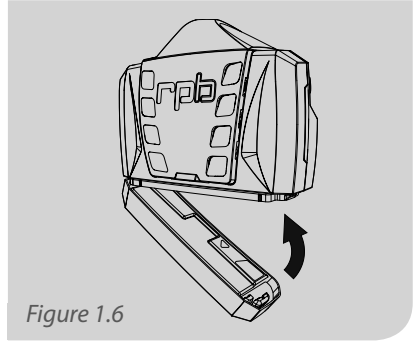
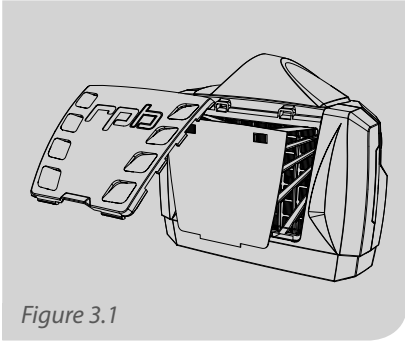

Figure 1.6

Now attach the battery to the RPB PX4 AIR by connecting the left hand edge to the base of the unit and rotate up into position, making sure that the latch snaps into place.

rpb[®] PX4 AIR PAPER

HIGH EFFICIENCY FILTER



A 03-981 Pre-filter is mounted in front of the 03-985 HE filter to prolong the life of the Filter.

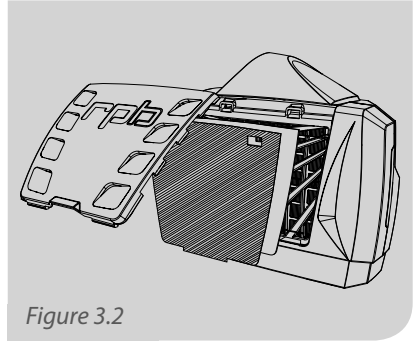

Check your environments. For use in environments with Sparks or molten metal, use the 03-982 Spark Arrester in front of the 03-981 Pre-filter. This will reduce the risk of fire.

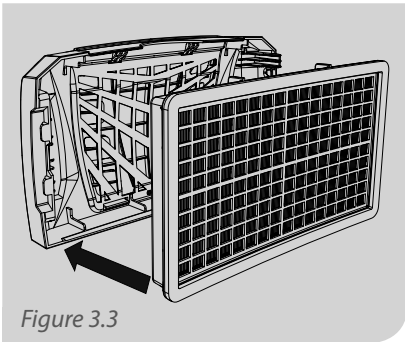

Mount the 03-985 HE Filter into the Door, note the logo on the front of the Filter should be to the bottom.

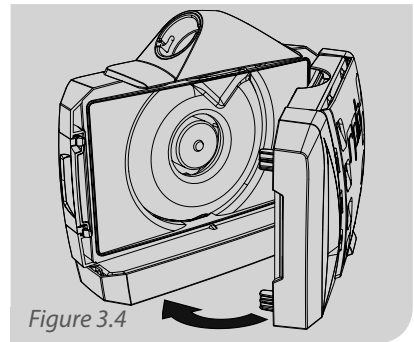

Slide the Door on to the hinge block on the right side of the fan unit as you face it, rotate the door to the left and latch in place.

TO REPLACE THE HE FILTER

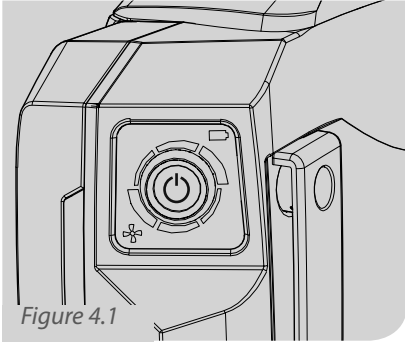

Figure 4.1

Make sure the 03-911 fan unit is switched off before attempting to open the Door. (Note: Press and hold button to power off.)

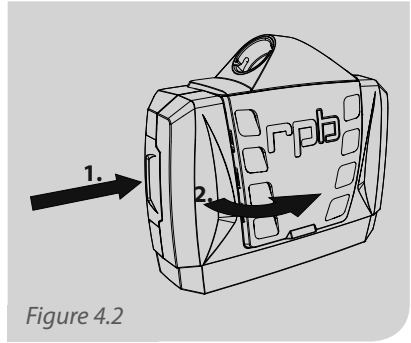

Figure 4.2

(1.) Depress the latch, (2.) rotate the door to the right and lift the door off the latch.

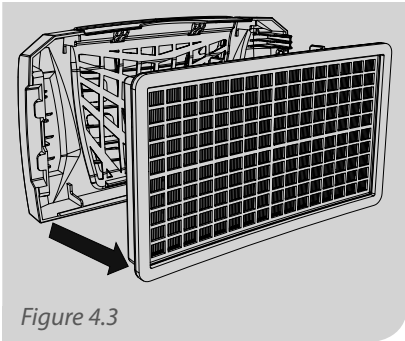

Figure 4.3

Remove the 03-985 filter from the Door and dispose of it in a suitable way. (Note: treat the old filter with care as the contaminants on the outside of the filter may be dangerous to your health).

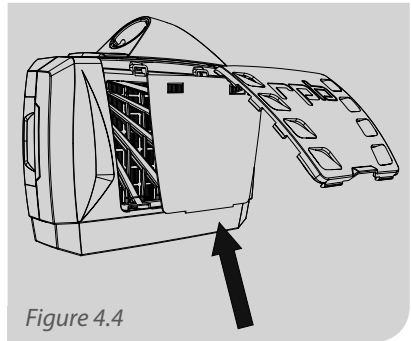

Figure 4.4

Install the new replacement 03-985 filter as per Fig 3.3 and 3.4. Inspect the 03-981 Pre-filter and replace as needed.

rpb[®] PX4 AIR PAPER

POWER ON/OFF BUTTON AND SPEED CONTROL

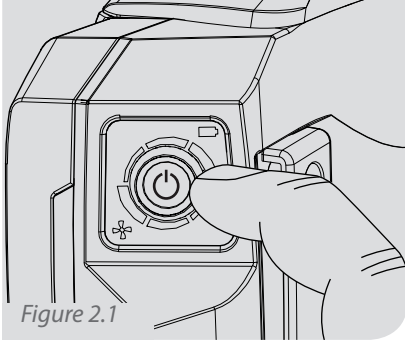

Figure 2.1

The Power button is on the right of the unit as you look at the front of the PX4. **POWER ON:** Press and hold the power button (for about 1 second). Note the unit will always start up in the low speed setting and should reach nominal flow within 5-10 seconds. Allow the unit to warm up for 5 minutes or until the flow meter (04-091) is in the safe range before use.

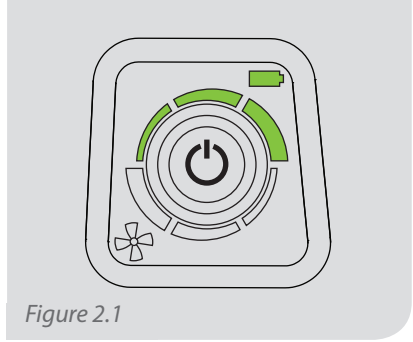

Figure 2.1

The top row of green lights indicate the charge of the battery. 3 lights is fully charged. 1 light means the battery is getting low. When it is time to change or charge the battery, there will be 1 light flashing alternately green and red.

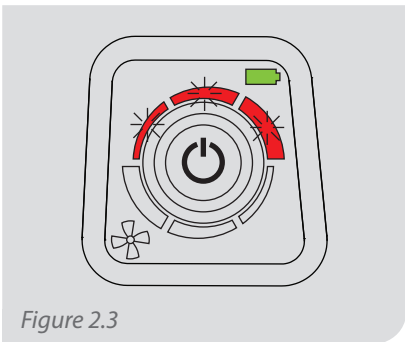

Figure 2.3

When the battery is out of charge the top row of lights will flash red and the alarm will sound. Immediately return to a safe environment and remove the respirator and change/charge the battery.

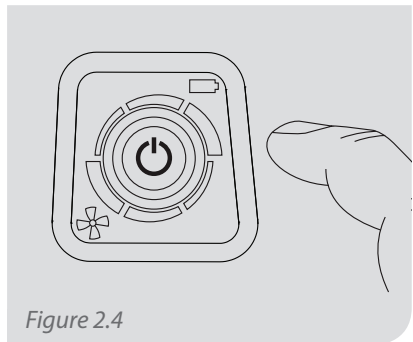
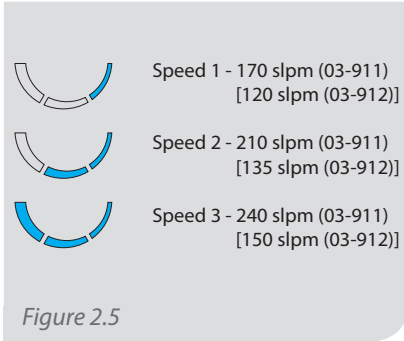

Figure 2.4

POWER OFF: Press and hold the power button (for about 1 second) and the unit will turn off. See Fig 6.3.

FAN SPEED AND AIR BLOCKAGE INDICATION



Speed Settings: Cycle through the 3 speed settings by pressing the Power Button. Each button press will advance through these speed settings.

OPERATION LEGEND

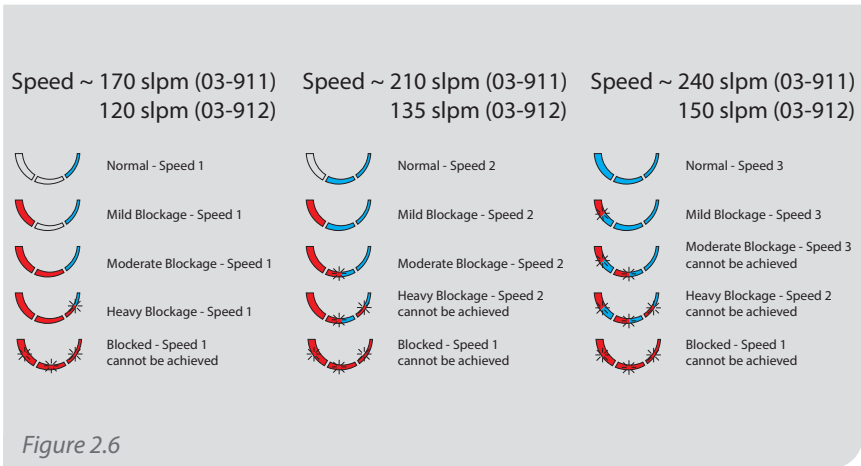

The blue lights indicate the selected fan speed. The red lights indicate the level of blockage. When the lights flash red and blue, the selected fan speed cannot be reached, but sufficient air supply (170slpm 03-911, 120slpm 03-912) can still be reached. When 3 lights flash red, the alarm will sound indicating insufficient air supply is being produced. Return to a safe environment and check the filter and/or the airway for blockage. If the filter is contaminated, replace with a new cartridge.

rpb[®] PX4 AIR PAPER

BREATHING TUBE

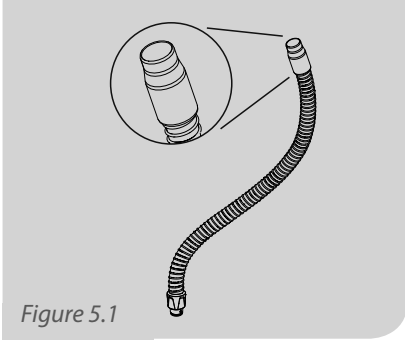

Select the Flexible breathing tube that suits your respirator (check the fitting connects to your respirator type). Ensure that the seal is in place.

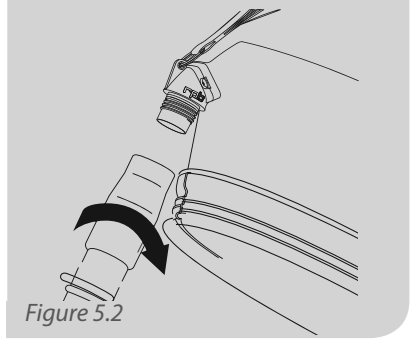

Take the end that fits to the Respirator and connect it securely.

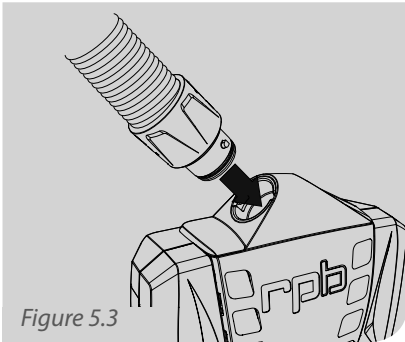

Now take the bayonet end, insert the connection into the PX4 and make sure the 2 small pegs line up with the slots in the PX4 outlet.

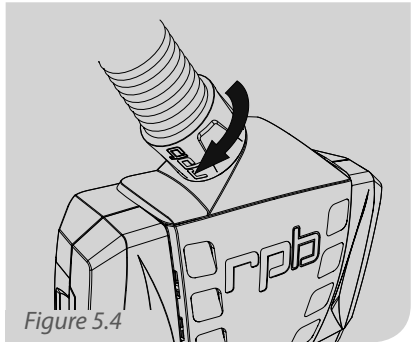

Twist the breathing tube to the right a $\frac{1}{4}$ turn to lock into position. Make sure that it is fully locked in position.

BELT AND SUPPORT ATTACHMENT

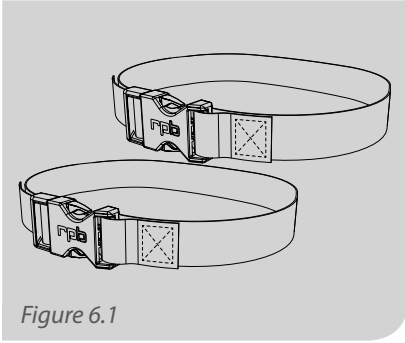

Figure 6.1

Choose the appropriate belt for the working environment; (07-765 Polyethylene Belt and Buckle {Standard} or 07-765-FR Nomex® Belt and Buckle {Welding and High Heat Applications}).

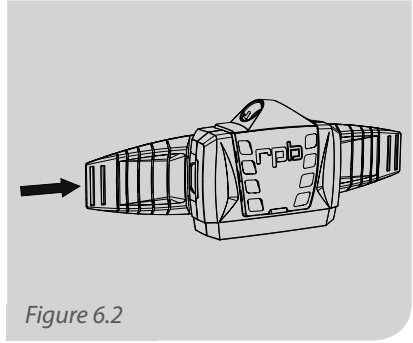

Figure 6.2

Thread the belt through the support in a left to right flow when looking at the front of the PX4.

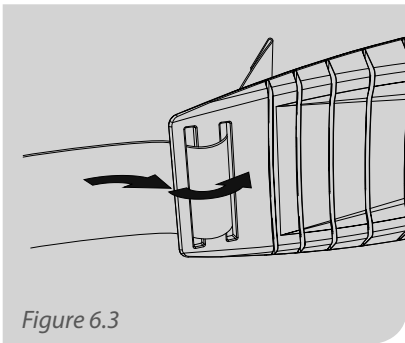

Figure 6.3

Take the loose end of the Belt and thread from behind through the outer slot (slot furthest out from the PX4) in the left support and then back through the inner slot (Closest to the PX4).

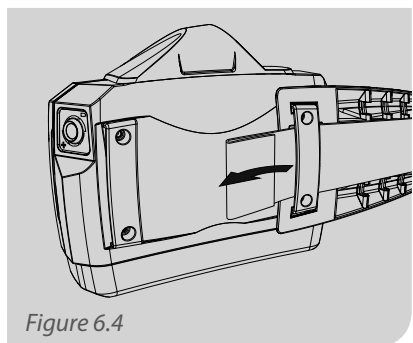
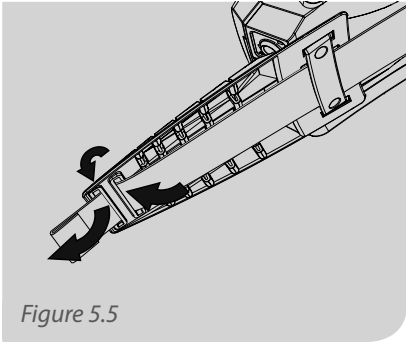

Figure 6.4

Thread the belt through the belt loop so that it passes between the loops and the support.

rpb[®] PX4 AIR PAPER

BELT AND SUPPORT ATTACHMENT (CONTINUED)



Thread the belt through the inner slot from the back and then back through the outer slot, see Fig 5.5.

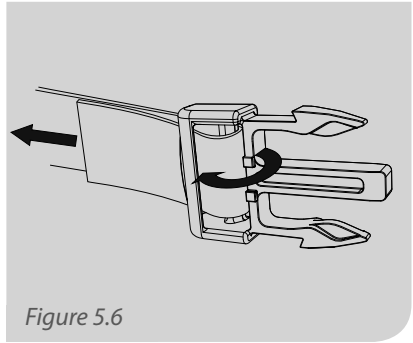

Now thread the clip end of the buckle on to the belt and pull to the desired length, see Fig 5.6.

APPARATUS CLASSIFICATION AND PROTECTION FACTOR

TABLE 1.1

European Device Classification	APPARATUS MODEL	NOMINAL PROTECTION FACTOR	PARTICULATE FILTER 03-985
EN 12941 TH3	NOVA 3	500	10,000
EN 12941 TH2	Z3	50	575

RESPIRATOR OPERATIONS (CONTINUED)

Inspection, Disinfecting and Cleaning

Before each use, the unit should be inspected for the following points. This helps to determine that the unit is operating as it was designed and it is suitably protecting the operator:

1. **PX4 AIR PAPR SYSTEM:** Make a visual inspection of the entire unit, which includes the motor housing, filter door and door cover, filter and pre-filters, battery, belt and breathing tube. Also inspect that the correct hood or face pieces is attached.
2. **BATTERY PACK:** Check that the battery has a full charge (see the battery test strip on the top of the battery, Fig 1.5) to confirm that there is sufficient charge for the work period that you need to accomplish. Make sure that the battery is securely fitted to the PX4 AIR PAPR.
3. **BREATHING TUBE:** Inspect the breathing tube completely, looking for splits and cracks in the tube, the fittings are held securely in the tube and that the O-ring is in place on the bayonet fitting that inserts into the PX4. Make sure that the breathing tube fits firmly into the PX4 unit and seals without any leaks around the connection. See Fig 4.3 and 4.4
4. **HE FILTER:** Inspect the filter casing for cracks and distortions that will affect the seal to the PX4 unit. Inspect the filter paper and the seal carefully for any of the following defects; dirt, cuts and tears, distortions or indentations. The seal can be wiped clean with a damp cloth to remove dirt particles, (do not use solvents or detergents. The HE filter paper must not be cleaned or submersed in water at any time. Damage to the HE filter paper will affect its ability to filter the air and could expose users to harmful environments. All damaged filters, pre-filters and spark arresters must be replaced before using the PX4.
5. **AIRFLOW METER:** Check the ball in the 04-091 airflow meter is moving freely. Insert the flow meter into the outlet of the PX4 and rotate $\frac{1}{4}$ turn to lock in place so that it is sitting vertical. Turn on the PX4 and let the air stabilize over a 30 second period. With the meter still in the vertical position check that the ball

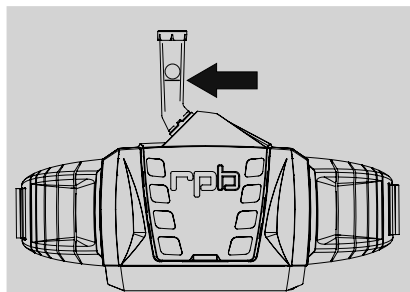

Figure 7.1

rpb[®] PX4 AIR PAPER

RESPIRATOR OPERATIONS (CONTINUED)

is sitting above the minimum flow rate marker.

WARNING! Do not use the PX4 if the meter does not reach the minimum airflow rate of the flow meter. Low airflow will increase the level of protection provided.

Ser Fig. 7.1

6. **ALARM SIMULATION:** Check the operation of the airflow alarm is functioning correctly. Power on the PX4 and place the palm of your hand over the outlet of the PX4. Continuing to hold your hand tightly over the outlet, with the airflow restricted until the alarm sounds, (audible alarm and Red LED indicators on the button) after 5-10 seconds, indicating the airflow is below the minimum airflow. Remove your hand and the alarm and LED should return to normal operation once the airflow is back to safe levels.
7. **CLEANING & DISINFECTING:** The PX4 unit can be cleaned with a damp cloth and mild detergent on the external surfaces and the face of the fan motor housing.

WARNING! DO NOT submerge in Water or use solvents on any parts of the PX4. This device has electrical components and could cause injury or death if put in contact with water.
8. **STORAGE:** The PX4 should not be stored with the Filter or battery attached if not being used for long periods of time, store in a clean, dry environment, away from direct heat sources between -10°C and +45°C, at a relative humidity of less than 90%. All batteries must be stored in a cool dry atmosphere.

DO NOT use, store or charge a battery in ambient temperatures that exceed (40°C). All filters must be stored in an airtight plastic bag or container so that they are not exposed to contamination.
9. **BELT LOOPS/SUPPORTS:** Check the Belt Supports and Belt Loops for cracks. If cracks or excessive wear is present, they should be replaced. To replace the Belt Supports (03-965) and the Belt Loops (03-924), unthread the Belt from the Belt Supports and the Belt Loops. Remove the Belt Loops by removing the two screws in each Belt Loop. Remove the old Belt Supports and place the new ones. Place the new Belt Loops and screw in tight until secure. Do not over tighten.

PRODUCT SPECIFICATIONS AND DATA

TABLE 1.2

AIR FLOW	<p>Speed 1: Greater than 170slpm (Nominal 180slpm) [120slpm, Nominal 130slpm (03-912)]</p> <p>Speed 2: Greater than 210slpm [135slpm (03-912)]</p> <p>Speed 3: Greater than 240slpm [150slpm (03-912)]</p>
OPERATING TEMPERATURE	<p>-10° to 40°C. If the unit is operated outside this temperature range for 10 minutes the battery alarm will activate.</p> <p>If the internal battery temperature reaches 60°C the unit will completely shut down.</p>
OPERATING NOISE	<p>Speed 1: 57 dBA at 300mm from the unit.</p> <p>Speed 2: 59 dBA at 300mm from the unit.</p> <p>Speed 3: 62 dBA at 300mm from the unit.</p> <p>Note: readings were taken at the distance listed from the front of the unit when connected to a T100 Respirator at the 3 speed settings.</p>
STORAGE TEMPERATURE	<p>-10° to 45°C at a Relevant Humidity of less than 90%. RPB® recommends that the device is store at 10° to 30°C as the optimal temperature range for storage, to maximise the life of the battery.</p>
BATTERY RUN CONTENTS TIMES	<p>Lithium-polymer</p> <p>Speed 1: 10-13 hours</p> <p>Speed 2: 7-10 hours</p> <p>Speed 3: 6-8 hours</p> <p>Note that these times are estimated from testing using a new battery and new clean filter at 21°C. These times could be longer or shorter depending on environments and configurations.</p> <p>Note: you should consult with your transport agent specialist before transporting Lithium-polymer batteries.</p>
BATTERY CHARGING	<p>3 hours</p>
ALARMS: LOW AIRFLOW	<p>A continuous alarm sounds when the airflow to the hood falls below the minimum requirement of 170slpm for more than 10 seconds in duration.</p>
LOW BATTERY CHARGE	<p>A continuous alarm sounds when approximately 10-15 minutes of charge is left in the battery. Power the unit off and remove the battery and place on charge, if you have a second battery you can connect to the device to continue operation. The continuous alarm will also sound if the battery is overheating.</p> <p>Alarm volume is 85 dBA at 104mm.</p>

rpb[®] PX4 AIR PAPER

PRODUCT SPECIFICATIONS AND DATA

(CONTINUED) TABLE 1.2

PRODUCT STORAGE LIFE (FROM NEW IF KEPT IN ORIGINAL SEALED PACKAG- ING)	
A. MOTOR/FAN UNIT	A. 5 years
B. BATTERY PACK	B. 1 year
C. FILTERS	C. 5 years
INTRINSIC SAFETY	The PX4 is NOT classed as an Intrinsically Safe Device.
ASSIGNED PROTECTION FACTOR (APF)	The assigned protection factor is dependent on the type of respirator used with the PX4. Please refer to table 1.1 for confirmation.

TROUBLE SHOOTING

TABLE 1.3

LOW AIRFLOW ALARM	A continuous alarm sounds when the airflow to the hood falls below the minimum requirement of 6cfm (170slpm) for more than 10 seconds in duration.
LOW BATTERY CHARGE ALARM	A continuous alarm sounds when approximately 10-15 minutes of charge is left in the battery. Power the unit off and remove the battery and place on charge, if you have a second battery you can connect it to the device to continue operation. The continuous alarm will also sound if the battery is overheating. Alarm volume is 85 dBA at 4" (104mm).
BATTERY SHORTING	If the battery shorts a slow flashing green light will appear in the battery test strip. To reset the battery, place the battery pack on the charging station.

rpb[®] PX4 AIR PAPER

PARTS AND ACCESSORIES

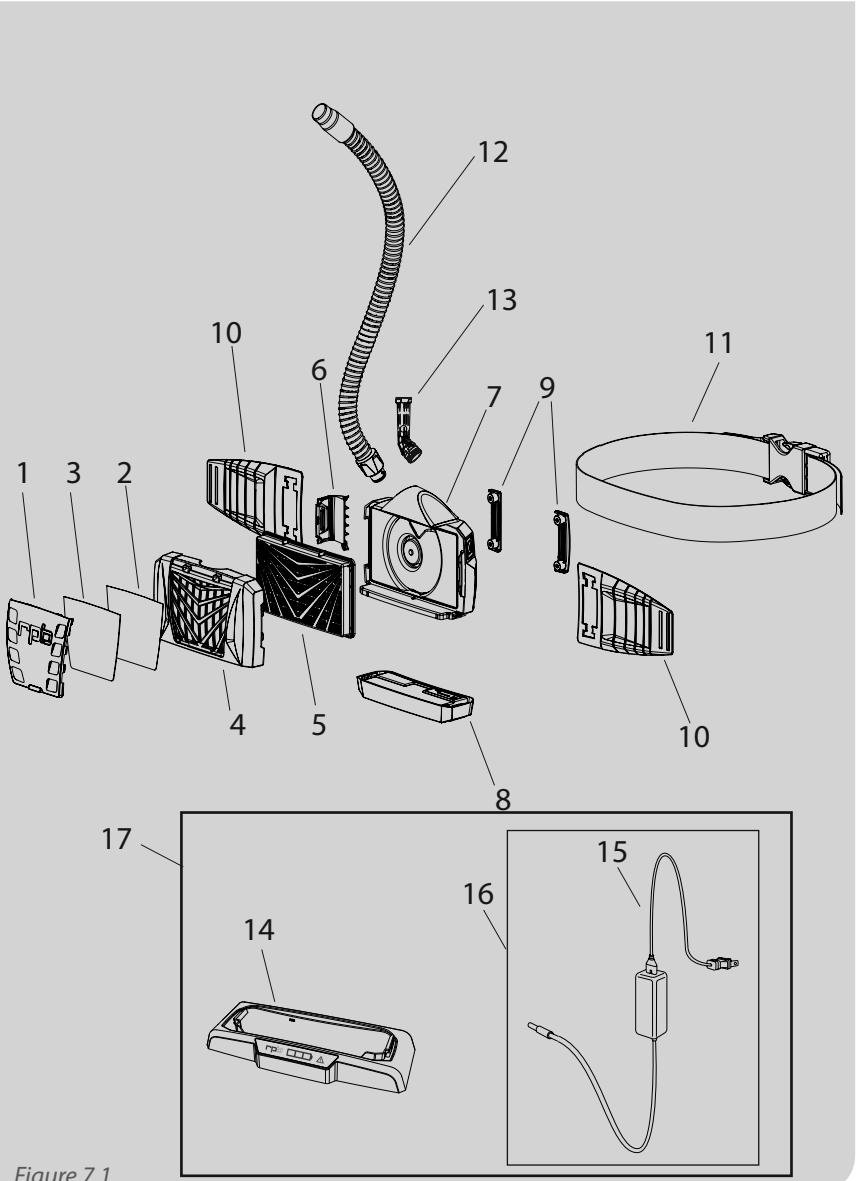

Figure 7.1

PARTS LIST

Item Number	Description	Part Number
1	PX4 Cover	03-922
2	PX4 Prefilter (Packet of 10)	03-981
3	PX4 Spark Arrestor	03-982
4	PX4 Main Door	03-921
5	PX4 High Efficiency Filter	03-985
6	PX4 Latch Kit	03-923
7	PX4 Fan Housing	03-911
	PX4 Fan Housing - Low Flow (dk gray fan cover)	03-912
8	PX4 Battery	03-955
9	PX4 Belt Loop Kit	03-924
10	PX4 Belt Supports (Pair)	03-965
11	PX4 2" Belt and Nylon Buckle	07-765
	PX4 2" Nomex® Belt and Acetyl Buckle	07-765-FR
12	PX4 Air Breathing Tube & Hose Clip (T100, Z100)	04-836
	PX4 Air Breathing Tube (Nova 3°)	04-838
	Px4 Air Breathing Tube (Z3, T150)	04-839
13	PX4 Air Flow Meter	04-091
14	PX4 Battery Charger	03-951
15	AC Power Cable - USA 2 pin	09-021
	AC Power Cable - UK 2 pin	09-021-UK
	AC Power Cable - EU 3 pin	09-021-EU
	AC Power Cable - AU 2 pin	09-021-AU
16	24 Volt Power Supply with Power Cord	03-952
	24 Volt Power Supply with Power Cord - AU	03-952-AU
	24 Volt Power Supply with Power Cord - EU	03-952-EU
	24 Volt Power Supply with Power Cord - UK	03-952-UK
17	PX4 Battery Charger and Power Supply Kit	03-950
	PX4 Battery Charger and Power Supply Kit - AU	03-950-AU
	PX4 Battery Charger and Power Supply Kit - EU	03-950-EU
	PX4 Battery Charger and Power Supply Kit - UK	03-950-UK

rpb[®] PX4 AIR PAPER

NOTES

A series of horizontal dotted lines for writing notes.

OTHER PRODUCTS

ISO9001
CERTIFIED COMPANY

RPB® NOVA 3® RESPIRATOR

The RPB® NOVA 3® combines breakthrough protection technology with advanced comfort and functionality, surpassing even the most rigorous industry standards and the demands of the most quality-conscious companies. Designed to optimize safety and productivity, and to minimize worker downtime, the helmet has a host of features that maximize its lifetime value.



RPB® Z3® WELDER

The RPB® Z3 Welder combines respiratory protection with breakthrough optical technology, providing welding professionals with a comfortable working environment. Features on the RPB® Z3 surpass even the most rigorous industry standards and the demands of the most quality conscious companies.



RPB® T100 RESPIRATOR

The T100™ supplied air respirator, manufactured from DuPont® Tychem® is a lightweight hood offering superior comfort compared with a conventional, tight full-face respirator. The hood also protects the entire head of the operator eliminating the need for a head sock. The wide angle lens offers optimum vision to set a clear view of the job.



1 866 494 4599
www.rpbsafety.com

rpb®
ADVANCING
YOUR SAFETY